



This is a digital copy of a book that was preserved for generations on library shelves before it was carefully scanned by Google as part of a project to make the world's books discoverable online.

It has survived long enough for the copyright to expire and the book to enter the public domain. A public domain book is one that was never subject to copyright or whose legal copyright term has expired. Whether a book is in the public domain may vary country to country. Public domain books are our gateways to the past, representing a wealth of history, culture and knowledge that's often difficult to discover.

Marks, notations and other marginalia present in the original volume will appear in this file - a reminder of this book's long journey from the publisher to a library and finally to you.

### **Usage guidelines**

Google is proud to partner with libraries to digitize public domain materials and make them widely accessible. Public domain books belong to the public and we are merely their custodians. Nevertheless, this work is expensive, so in order to keep providing this resource, we have taken steps to prevent abuse by commercial parties, including placing technical restrictions on automated querying.

We also ask that you:

- + *Make non-commercial use of the files* We designed Google Book Search for use by individuals, and we request that you use these files for personal, non-commercial purposes.
- + *Refrain from automated querying* Do not send automated queries of any sort to Google's system: If you are conducting research on machine translation, optical character recognition or other areas where access to a large amount of text is helpful, please contact us. We encourage the use of public domain materials for these purposes and may be able to help.
- + *Maintain attribution* The Google "watermark" you see on each file is essential for informing people about this project and helping them find additional materials through Google Book Search. Please do not remove it.
- + *Keep it legal* Whatever your use, remember that you are responsible for ensuring that what you are doing is legal. Do not assume that just because we believe a book is in the public domain for users in the United States, that the work is also in the public domain for users in other countries. Whether a book is still in copyright varies from country to country, and we can't offer guidance on whether any specific use of any specific book is allowed. Please do not assume that a book's appearance in Google Book Search means it can be used in any manner anywhere in the world. Copyright infringement liability can be quite severe.

### **About Google Book Search**

Google's mission is to organize the world's information and to make it universally accessible and useful. Google Book Search helps readers discover the world's books while helping authors and publishers reach new audiences. You can search through the full text of this book on the web at <http://books.google.com/>

TL  
233  
.H6

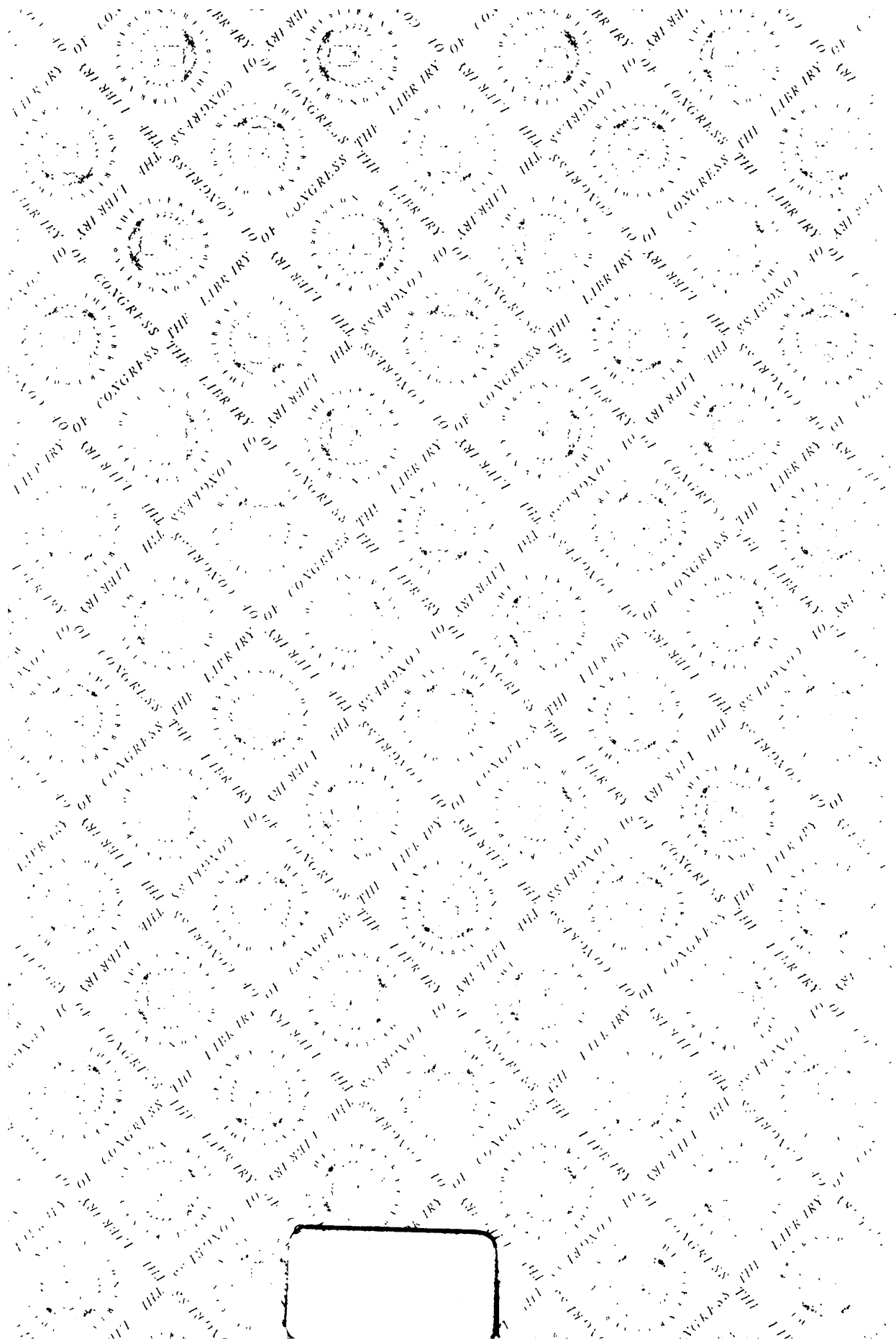



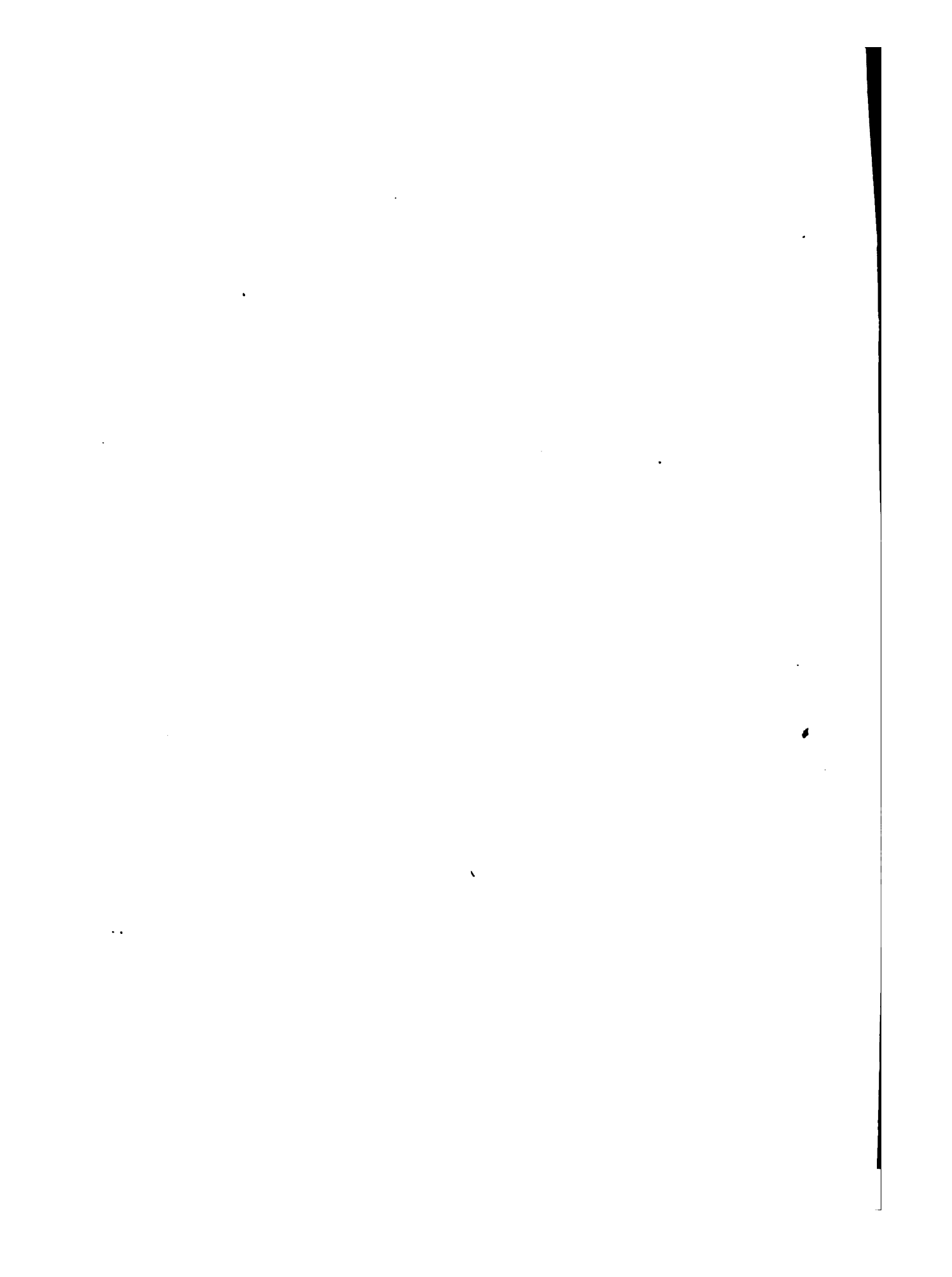

CARE AND OPERATION  
OF  
"CATERPILLAR"  
Tractor Type 45  
45 TRACTOR

---

THE HOIT MANUFACTURING  
C O M P A N Y  
INCORPORATED  
MOUNTAIN VIEW, CALIFORNIA



Care and Operation

*of the*

**“CATERPILLAR”**

T. M. Reg. U. S. Pat. Off.

**45 TRACTOR**



**The Holt Manufacturing Company**

**Incorporated**

**Stockton, California**

**Peoria, Illinois**

**Copyright 1917  
by The Holt Manufacturing Company**



TL 233  
.H6

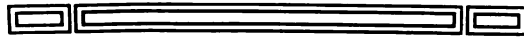

**E**XTRA COPIES of this  
book may be purchased  
from The Holt Manufac-  
turing Company at seventy  
five cents (\$.75) per copy.

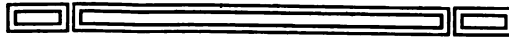

17-25884

OCT -8 1917

©CLA473897

new 6-16-17

## OVERLOADING

Overloading is a common practice among all traction engine owners. It is a peculiar circumstance that seems to lead all owners to try to make their engines do a little more work than that for which they were intended. Many owners, too, have learned by costly experience that it does not pay. Circumstances may arise, however, in which the returns from the work performed under overload will more than pay for the damage involved, but the operator should understand that the factory will not be responsible for breakage or damage when the tractor is overloaded.

To get the best results from the "Caterpillar" Tractor, or any other engine as a matter of fact, DO NOT OVERLOAD. If you work the tractor to the capacity advised by the factory, it will give the same steady service year in and year out. The draft required to work various kinds of soil varies enormously. *Be guided somewhat by the equivalent number of horses or mules required to pull the equipment that is placed behind the "Caterpillar" Tractor, in the locality where the work is to be performed.* If it is difficult for you to decide what is the proper load, write The Holt Manufacturing Company at once, and it will be a pleasure to tell you just what load you can successfully and economically handle.

# ORDERING

## Instructions for Ordering Extras

1. *In ordering extras, write the order on a separate sheet of paper.*

Orders placed in the main body of a letter will receive due attention, but orders for extras written on a separate sheet of paper will expedite our giving service to you.

2. State plainly your postoffice address, *then state the address*, County, and State to which the goods are to be sent, and whether the order is to go forward parcel post; *express, what route; or freight and what route.* State the number of the "Caterpillar" Tractor for which the extras are intended. See Service Bulletin A.

Some towns are served by more than two express companies, four separate railroad systems, or two river boat companies, in addition to parcel post. *It is necessary that you give the complete forwarding address.* Good service on our part starts in getting the order complete from you in the first place.

3. Order from the Price List of Parts book. Always give the part number complete, and follow it with the part name and description and quantity wanted. If in doubt send in sample. Be sure to state whether for right or left side.

4. **PREPAY ALL FREIGHT OR EXPRESS CHARGES ON SAMPLE CASTINGS OR EXTRAS SENT TO FACTORY.** *Identify the part by putting your name, address, and purpose for which the part was returned, on the tag.* Then write a letter stating the purpose for which the part was returned.

Never give us credit for being able to guess what is wanted, for we never attempt it, therefore, vexatious delays will be avoided by fully identifying the returned shipment with your name, address and purpose for which part was returned, in addition to writing a letter. Unidentified material is held fifteen days and if no advice is received the sample is passed to scrap.

## Instructions for Returning Goods

It is necessary for our customers, especially those who operate agricultural machinery, to have occasion to make return of sundry parts shipped them through error on our part, or through error of their own in not ordering correctly. In returning goods we wish our customers to observe the following instructions:

1. Place your name and address on the tag securely fastened to the part being returned. On this same tag state the purpose for which the part is being returned, such as repair, sample, inspection or examination for credit.

2. **PREPAY ALL FREIGHT OR EXPRESS CHARGES ON MATERIAL SENT TO THE FACTORY.**

3. Write a letter stating the purpose for which you are returning the part.

# CARE *and* OPERATION of "CATERPILLAR" 45 TRACTOR

## GENERAL DIRECTIONS *for* OPERATION

### First Putting the "Caterpillar" Tractor in Service.

- 1 — If the "Caterpillar" 45 Tractor has been received by freight, the engine will be completely boxed in and the tractor will be securely blocked on the car. Remove the boxing from the engine and the cleats from the car that brace the "Caterpillar" Tractor.
- 2 — All the grease cups on the exterior of the tractor are removed at the factory; corks are inserted where the grease cups are removed and the grease cups are placed in a sack and boxed in with the engine. Before moving the "Caterpillar" Tractor it is necessary to put the grease cups in the places where corks are found. No grit or dirt should be allowed to gain entrance into a grease cup hole or to become incorporated with the cup grease. Fill gudgeon oil cups with transmission oil.
- 3 — *Fill all grease cups with "Caterpillar" Cup Grease and screw down until grease is forced out the end of the bearing. This, then, eliminates all chances for air holes in the grease grooves and gives the correct starting point for lubrication. If grease is kept in, dirt will be kept out.*
- 4 — *The first duty of a "Caterpillar" Engineer is to keep his supply of oil and cup grease scrupulously clean. The least trace of dirt and grit introduced into a bearing causes cutting in the bearing surfaces and undue wear. Grit and the worn particles of metal will fill up the oil grooves and ultimately prevent any lubricant from reaching the desired point. A grinding compound is all right when used in its proper place, but it is not a lubricant in any sense of the word, nor is oil or grease containing grit a lubricant. Dirty oil and grease must always be treated as a grinding or cutting compound. An engineer's reputation depends upon keeping his lubricating agents scrupulously clean.*
- 5 — Fill the water tank with clean water. When the engine has been started and circulation has been established, fill water tank so that it overflows, thus insuring the radiation system being completely filled.
- 6 — With a piece of waste wet with distillate, wipe the crankcase doors on the right hand side of the engine, remove doors, and examine the lubricating oil supply. The oil levels under each cylinder should be to the top of the overflow pipe. A measuring stick absolutely free from dirt should be inserted into one of the overflow pipes in the oil pits, allowed to descend till stopped by the bottom of the crankcase and should show at least one inch of oil on the bottom of the stick. If this condition does not exist, fill the crankcase with "Caterpillar" Cylinder Oil till the oil shows at least one inch on the stick. See Fig. 4.

---

## CARE AND OPERATION

---

- 7 — Revolve the engine by hand and be sure that the dippers on the end of the connecting rods are all in place and that they dip into the oil level at least  $\frac{1}{8}$ ". It is absolutely necessary that these fingers throw the oil as the wrist pins, bushings, piston rings and all bearings inside the crankcase depend on this for their lubrication.
- 8 — See that the mechanical oiler is filled with "Caterpillar" Cylinder Oil.
- 9 — See that the fuel tank is filled.
- 10 — Examine the pump and fan belt. A loose belt on the water pump is especially dangerous. After an engine has been idle for some time the pump pulley generally turns stiff until it is warmed up, and if the belt is loose it will fail to turn. The pump pulley must turn in order to circulate the water through the engine. Be sure that the pulley is tight on the shaft.
- 11 — Oil the rocker arms on the engine. Oil the governor plunger, particularly the extreme end of the plunger towards the flywheel. Throw master clutch, Fig. 42, page 81, to "Out" position and lubricate the plates 1630SB and 1631 SB thoroughly with cylinder oil. Lubricate the bronze shifting collar 1068 SB by turning down grease cup and oil all the friction dogs with cylinder oil. The grease cup, which is shown in the lower half of Fig. 36, supplies grease to the SKF ball bearing on the ends of the crankshaft, over which the master clutch rides. This bearing should receive a medium grade of cup grease and the lubrication of it should never be neglected. This cup should be given one turn per hour if the engine is run idle. Fill the oil cups of the transmission with "Caterpillar" Cylinder Oil and adjust to drop fifteen drops per minute. When the tractor has been "run in" under load, reduce the feed to ten drops per minute. Fill the grease cup on the end of shaft 4637 SS shown in Fig. 44, page 87, with "Caterpillar" Cup Grease. This grease cup supplies grease to the floating bushing B 307, which is perforated with a great number of holes to retain lubrication. Always be sure that this part is securing its proper supply of oil. Fill the reservoir in the sleeve hub, Fig. 44, with transmission oil. Fill the oil cups M 1580 on all truck wheels with transmission oil. *Never use crude or fuel oil in the truck rollers.* If black oil of guaranteed grade is being used on the track, then this oil can be used in the truck rollers. Lubricate the starting lever and stationary attachment where the grease cups are shown. See Fig. 35 and paragraph 234.

### Second

### Starting Engine

- 12 — See that the master clutch is disengaged. If it is engaged it might cause trouble and be hazardous to life.
- 13 — *Retard the spark.* Trip the ratchet catch lock ST 14 on the HK or TS 8 for the TK K-W Magneto to put the impulse starter into operation. See paragraphs 183 and 190.

(NOTE.) At full retard position, which is the lever position closest towards driver's seat, a short-circuiting switch engages the low tension lead and short circuits the magneto. Before starting the spark lever should be advanced a trifle past the position required to disengage the short circuiting switch. *The spark lever, however, should never be advanced more than  $\frac{1}{8}$  the range from full retard when starting the engine.*

- 14— Advance the gas lever from the rear of the quadrant to about  $\frac{1}{4}$  position towards the engine. *Some operators start the engine with the throttle wide open.* This is a great mistake. Too much “wet gas” on a cold morning hinders starting.
- 15 — Open the priming cups and give each cylinder two or three squirts of gasoline from a priming can. Prime the carbureter with gasoline. **Do not over-prime the cylinders with gasoline.** Over-priming with gasoline will wash off the piston ring and cylinder wall lubrication. It must always be remembered that the lubricating oil film between the pistons, piston rings and cylinder walls is the final seal to retain compression and must never be destroyed by over-priming.
- 16 — *If an engine refuses to start and has been primed several times, or if an engine has stood idle for a long period of time, remove the spark plugs and insert with an oil can about three tablespoons of cylinder oil in each cylinder and revolve the flywheel several times until the lubrication film is established and compression becomes effective. Trouble with excessive carbon deposit under top piston ring or a piston ring cemented in the top piston ring slot is almost always directly chargeable to over-priming the cylinders in starting.* When the lubrication film under the top piston ring has been destroyed by raw gasoline, damage always results.
- (NOTE.) Following are some suggestions for starting a warm or hot engine:
- (a) If the engine is fairly hot, attempt to start without any priming. If the engine refuses to start without priming, *prime with distillate only.*
- (b) If the engine is only fairly warm, prime with gasoline only. Use the least amount possible.
- If the engine refuses to start under usual procedure of priming:
- (c) Remove spark plugs; clean porcelains till bright; reassemble; be sure that the spark plug points do not separate more than  $\frac{1}{64}$ ”; wet the end of the spark plug with gasoline. It is extremely important to keep the porcelain of the spark plug bright and clean.
- 17 — Close the priming cups.  
Open compression cocks.
- 18 — Revolve the engine by the starting lever and ratchet, holding the flywheel firmly on compression stroke and give it a quick flip past center. See paragraph 234, page 74. Unless the engine has been over-primed, starting the engine is an easy operation. *Be sure short circuiting switch on magneto is disengaged.*
- 19— When the engine starts:
- (a) Close compression cocks.
- (b) Advance the spark.
- (c) See that the radiation water is circulating.

*The moment that the engine starts, it is vital for the engineer to determine if circulation is taking place correctly. If not, the fault must be remedied. Impaired or poor circulation can cause scoring of pistons and cylinders immediately, regardless of the quality of oil used.*

---

## CARE AND OPERATION

---

(d) See that the fan is running.

(e) Determine if any slippage is occurring on pulley that drives circulating pump.

(f) Be sure that the pump is not drawing air through the brass glands.

(g) See that the oil is circulating in crankcase sight feed oiler. *If the sight feed clogs up, shut the engine down immediately and remedy condition.*

If any distributor pipe clogs up and the sight feed oiler doesn't show all streams running, shut the engine down and remedy condition.

Examining the crankcase oil supply every day and keeping the engine base oil supply clean will obviate any failure of oil circulating system.

(h) Never allow engine to operate with one or more "missing" cylinders, whether starting or pulling a load. The crankshaft is the member that suffers if this condition is allowed to exist, and serious damage can be done.

### Third

### Starting the Load

- 20 — Advance the spark lever by moving lever towards engine to the required position. (Never operate the engine on a load with retarded spark except for short intervals in heavy work.) Give the engine more gas by advancing the throttle towards the engine.
- 21 — *Do not allow the engine to race.* When ready to start, apply the clutch gradually until all slack between the "Caterpillar" Tractor and load is taken up, then *pull the clutch in firmly and without jerking.*
- 22 — Run the engine as near the speed marked on the name plate (600 R. P. M.) as possible. This will give the greatest power and most economical operation. *Correct lubrication and cooling also depend upon keeping engine up to speed indicated.*
- 23 — If the engine does not run at the required speed, there may be some setting on the governor to account for it. Refer to Fig. 15, page 39, and paragraphs 144 and 145, page 39, for the governor adjustment. *Never attempt a governor adjustment while the engine is in motion.* On engines that drive electrical lighting outfits it is necessary that the engine be kept up to speed indicated on the name plate to turn generator fast enough to generate proper current.

### Fourth

### Running

- 24 — Steering the "Caterpillar" Tractor is accomplished by disengaging the cone clutch on the steering shaft assembly on the side in the direction in which it is desired to go. The release of the cone clutch can be gradual to make an easy turn, but it can be immediately disengaged for short turning. To steer the tractor towards the right, pull the steering arm towards the driver's seat. To turn left, shove the steering arm away from the driver's position. A brake is also employed on each cone housing and if it is desired to turn short, the brake is applied on the same side that the clutch is disengaged.
- 25 — *In pulling a load, always pull from the swinging drawbar-position. Do not pin the drawbar to a fixed position unless for work which occupies a short period of time.* Pulling from the swinging drawbar facilitates making turns with the tractor.

- 26** — In descending hills, the speed can be regulated by closing the throttle and possibly retarding the spark. The K-W Magneto can be short circuited by means of the switch and the compression of the engine employed as a brake. This operating condition is rare. Of course, the brakes can be used at all times required.
- 27** — NEVER OIL THE “CATERPILLAR” TRACTOR WHEN IN MOTION. *The “Caterpillar” Engineer’s duty at all times when the tractor is in motion is to remain in his seat and have control over the tractor and load. If the engineer leaves his seat and becomes engrossed in lubricating parts or has his attention called otherwise, an accident may occur that will cause the engineer to lose his footing any may result in injury to body or limb and may be fatal to life.*
- 28** — In most plowing outfits a second man or “plow tender” is required to tend the plows and possibly other equipment and as his attention is not constantly required there, he has time to assist in lubrication. However, though the plow man or helper does this work, the “Caterpillar” Engineer is responsible for the oiling of the entire tractor and must see that it is done. *The “Caterpillar” Engineer must never direct a plow tender to oil a part of the “Caterpillar” when in motion that would be dangerous to life or limb.*
- 29** — The only time that the tracks can be lubricated is while the “Caterpillar” is in motion. The track should be well flooded with Black Oil about once an hour. However, many operating conditions vary and the engineer has to use his own judgment in most cases. *Crude and fuel oil should never be used to lubricate the tracks as they contain varying proportions of sand. “Caterpillar” Black Oil judiciously applied is a much better and more satisfactory lubricant.*

### **Fifth Stopping Temporarily**

- 30** — Disengage the master clutch.
- 31** — Close the gas throttle and retard the spark lever about one-half. If you wish to stop the engine, bring the spark lever clear to the end of the quadrant next to the driver, which will engage the short circuiting finger on the high tension magneto, stopping the engine.

### **Sixth Stopping at Night or End of Run**

- 32** — About 100 or 200 yards before the stop is made, open the compression cocks. This blows out any surplus oil and carbon in the engine and helps to make easy starting the next day.
- 33** — Close the throttle, retard the spark. *Instead of killing the engine on the magneto, shut off the distillate supply to the carbureter (by the fuel line valve and not the needle valve) and allow the engine to die from the want of fuel.* This will prevent any condensation of the vapors of distillate in the cylinders as they will be left entirely dry and warm. If the engine is killed by short-circuiting the magneto, one cylinder of the engine is always on compression and another has a fresh fuel charge in transit; the result is that when the



---

## CARE AND OPERATION

---

engine cools, the vapors of the fresh and compressed charge will condense, fall on the piston heads, may gain admission past the piston rings and ultimately find their way into the lubricating oil supply in the crankcase. *To keep the engine in perfect shape and to make easy starting, do not kill the engine on the magneto but close off the fuel line supply to the carbureter.*

- 34** — Turn off oil on tracks if running.
- 35** — In freezing weather, DRAIN RADIATOR, CYLINDERS AND PUMP. This is a very important matter. Your neglect to do this may cause serious and costly damage. The water, if left in the cylinders, may freeze and crack them open. Plugs are provided at the bottom of the water jacket on the magneto side of the engine to drain the water jacket entirely. When draining an engine, the operator should revolve it several times by hand in order to allow the head of water held by the centrifugal pump to be released. See paragraphs 206 to 212 on the care of the radiator.

### Lubrication

- 36** — Proper lubrication is the most important point that the tractor operator must consider, because upon this factor depends the life and efficiency of the tractor. IF LUBRICATING AGENTS OF THE PROPER GRADE ARE NOT SELECTED FOR THE DIFFERENT REQUIREMENTS OF THE TRACTOR, A HIGH STATE OF MECHANICAL AND COMMERCIAL EFFICIENCY CANNOT BE OBTAINED. THE HIGHEST REFINEMENT OF MANUFACTURING SKILL TO PRODUCE LONG LIFE IN THE FINISHED PRODUCT OF PARTS CAN BE TOTALLY UNDONE IN THE USE AND SELECTION OF THE WRONG LUBRICATING AGENTS. IF OILS AND CUP GREASES ARE NOT KEPT CLEAN THE BEST OILS AND GREASES WILL FAIL TO GIVE SATISFACTION.

### Friction

- 37** — *Friction is a conversion of useful work into useless heat accompanied by wear.* Friction can never be entirely eliminated in any mechanism, but by the use of suitable lubricating agents it can be reduced to a minimum.
- 38** — A complete statement of friction is not within the province of this Care & Operation Book, as it is a very large subject in itself. Friction is divided into two general classes: starting (static) and moving (kinetic) friction, and further divided into the friction of solids (external) and the friction of liquids (internal).
- 39** — Lubrication is the introduction of a smooth fluid or semi-fluid substance such as oil or grease between two moving surfaces to prevent solid friction, that is, to prevent the two metal surfaces from coming into direct metallic contact. *When moving parts are separated by a lubricant, friction then takes place within the liquid itself (internal friction).* *The significance of the part played by internal friction of the oil or lubricating agent is probably least understood by the tractor operator.* It is the lack of understand-

ing of this subject that causes the tractor operator to select the wrong type of cylinder oil and frequently the wrong lubricant for the transmission and other bearings. A light-bodied cylinder oil has an internal friction value different from that of a heavy-bodied cylinder oil. Cylinder oil that is right for a water-cooled engine has an internal friction value different from that of the oil suitable for an air-cooled engine, yet the latter is sometimes used in a water-cooled engine. The operator of a "Caterpillar" Tractor, however, has at his disposal results of exhaustive tests of oils which have enabled him to have the right body, together with low internal friction value, in "Caterpillar" Cylinder Oil.

- 40 — *The ideal condition of lubrication is to have a thin film of oil separating the sliding surfaces and circulating through the bearing fast enough to carry away the heat generated.*

### Requirements of the "Caterpillar" Tractor

- 41 — The kinds of oil required in the various parts of the "Caterpillar" Tractor are different. The oil that is used in the crankcase for cylinder lubrication must withstand high operating temperatures of the cylinders, and while lubricating the crankshaft and crank pin bearings must stand very heavy pressures under fairly high speeds; the oil used in the transmission must stand very heavy pressures under low speeds in order not to squeeze out and allow the teeth of the gears to come into metallic contact; the oil for the magneto must be a light oil to lubricate the ball bearings properly; the grease for the cups at the various parts must be a straight lubricating agent containing oil only and must not contain a filler either of vegetable, such as fiber or resin, or mineral, such as mica or graphite.

### Care of Lubricating Oil

- 42 — *The first duty of a "Caterpillar" Engineer is to keep his supply of lubricating oil and greases scrupulously clean. The least trace of dirt or grit introduced into a bearing causes cutting of the surfaces and undue wear. A valve grinding compound is all right in its proper place, but it is not a lubricant in any sense of the word. Dirty oil and grease must be considered a grinding or cutting compound. An engineer should be sure that all his containers into which he pours the oil are scrupulously clean and free from dust or grit. The crankcase doors of the engine should always be wiped clean with a rag or piece of waste saturated with distillate before removing to fill the crankcase with a new supply of oil. Sleeves should be brushed off so that no dirt will fall off from the clothing into the oil. All wrenches and bars used in the crankcase of the engine must be rinsed with distillate before working on the connecting rod or crankshaft bearings, thus minimizing the possibility of putting dirt into the oil. Water circulation should be effectively maintained at all times as scoring will result if the excess heat is not carried away. Cylinder oil is never intended to perform the function of circulation water.*

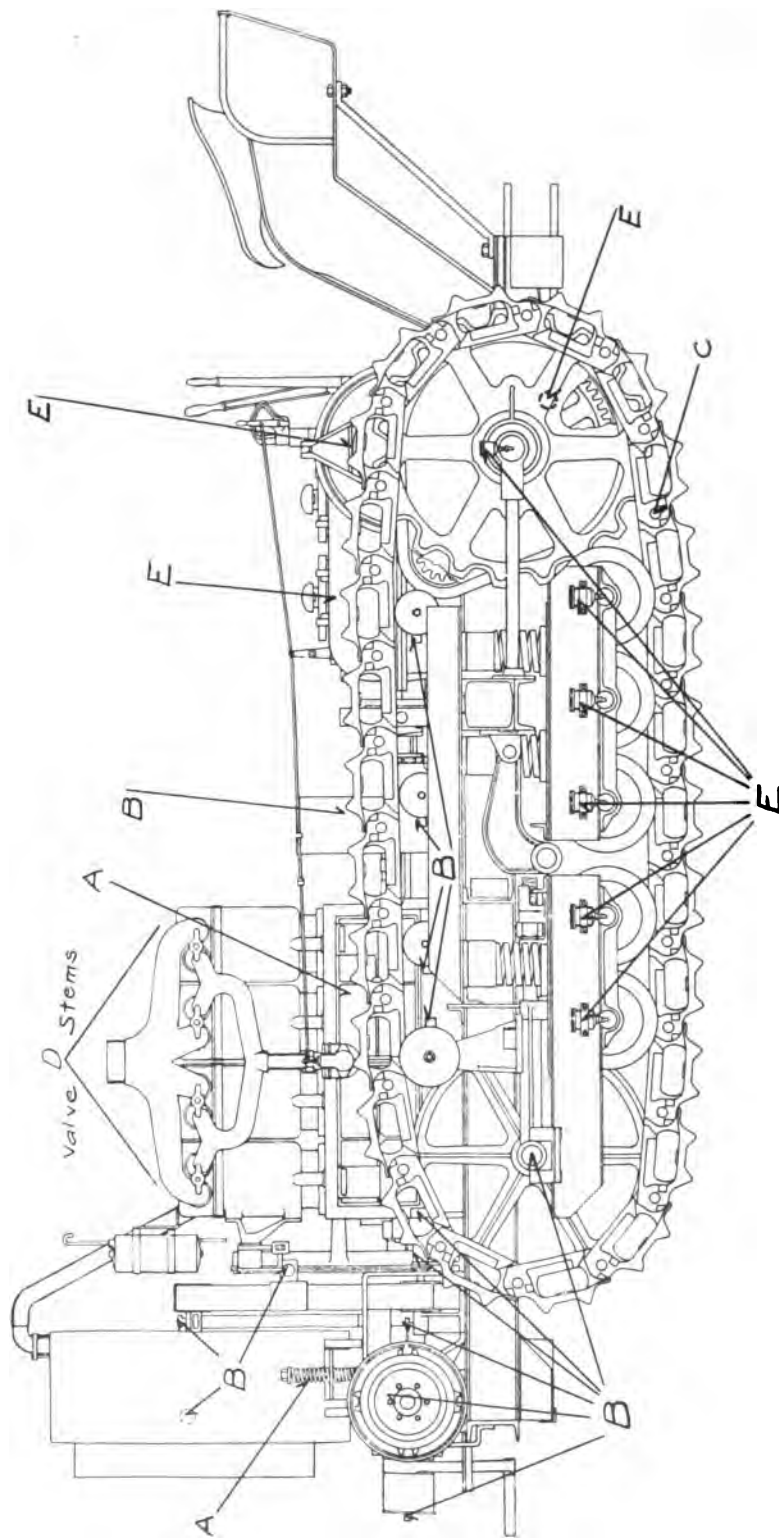

Fig. 1. Lubricating Chart.

## Care of Cup Grease

**43** — The operator must be careful never to allow the cup grease to get contaminated with dirt. *The one great consideration in using cup grease is to keep the cup grease in the bearing and the dirt out.* There are several grades of cup grease on the market ranging from a very stiff fiber grease to very soft bodied greases. A cup grease that is filled with fiber, mica or graphite is not recommended for use in any part of the “Caterpillar” Tractor, for the reason that in time under the action of heat these mineral or vegetable substances will be precipitated out and will clog the grease grooves and prevent the effective distribution of the new grease. “Caterpillar” Cup Grease has been especially developed for this tractor and its use in all grease cups is recommended. Cup grease should not be carried in an open container on the deck of the tractor. Keep cup grease covered.

## Lubricating Chart

44— PART	LUBRICANT	HOW APPLIED	HOW OFTEN
Fan shaft .....	Cup grease .....	2 grease cups.....	Two turns per hour.
Magneto shaft .....	Cup grease .....	2 grease cups.....	Two turns per hour.
Magneto .....	3-in-1 or Household Lubricant .....	Dropper .....	See par. 177 and 194.
Valve stems .....	½ Kerosene ½ Cylinder Oil.....	Oil can .....	Four times per day.
Rocker arms .....	Cylinder Oil .....	Oil can .....	Two times per day.
Governor .....	Cylinder Oil .....	Oil can .....	Two times per day.
Crankcase .....	“Caterpillar” Cylinder Oil .....	Oil filler .....	When required.
Mechanical oiler .....	“Caterpillar” Cylinder Oil .....	Reservoir .....	When required.
Air valve stem in carbureter .....	Cylinder Oil .....	Oil can .....	Two times per day.
SKF bearing in master clutch .....	Cup grease .....	1 grease cup.....	Two turns per day. If stationary work is being done give 1 turn per hour.
Master clutch discs.....	Cylinder Oil .....	Oil can .....	Two times per day.
Master clutch shifting ring .....	Cup grease .....	1 grease cup.....	Two turns per hour.
Master clutch dogs.....	Cylinder Oil .....	Oil can .....	One time per day.
Transmission .....	“Caterpillar” Transmission Oil ...	Oil filler .....	As required to maintain correct level.
Transmission bearings..	Cylinder Oil .....	3 oil cups.....	Fill every two hours.
Transmission bearings..	Cup grease .....	2 grease cups.....	Two turns per hour.
Shifter collar on steering clutch* .....	Transmission Oil ...	Grease gun .....	¼ pint every other day.

## CARE AND OPERATION

PART	LUBRICANT	HOW APPLIED	HOW OFTEN
External spur gear in dust guard* .....	Transmission Oil ....	Grease gun .....	Sufficient to keep gears dipping.
Drive sprocket hub.....	Transmission Oil ....	Grease gun .....	Fill once per day.
Drive sprocket shaft....	Cup grease .....	2 grease cups.....	Two turns per hour.
Track .....	Black Oil .....	Reservoir .....	Sufficient to keep space block and pin lubricated.
Truck wheels .....	Transmission, or refined Black Oil....	Oil cups .....	About ½ pint every ten hours.
Track carrier rollers....	Cup grease .....	8 grease cups.....	Two turns per hour.
Pivot shaft boxes (not shown on chart) .....	Cup grease .....	4 grease cups.....	Four turns per day.
Track idler shaft.....	Cup grease .....	2 grease cups.....	Two turns per hour.
Pump gland .....	Cylinder Oil .....	Oil hole .....	Fill four times per day.
Pump shaft .....	Cup grease .....	2 grease cups.....	Two turns per hour.
Starting crank assembly.	Cup grease .....	3 grease cups.....	Two turns per hour. See par. 237.
Stationary pulley assembly .....	Cup grease .....	3 grease cups.....	Two turns per hour when stationary pulley is running. Par. 237.
Stationary pulley assembly .....	Transmission Oil ....	Gear case .....	See par. 237.

\*Right and left sides.

The above recommendations, of course, are for guidance when the tractor is new. After the tractor is "run in" the engineer will vary the conditions to suit the different requirements.

### Care of Transmission Oil

- 45—** The oil for the transmission must be a straight mineral oil of proper body to withstand the squeezing pressure between the gear teeth, and still thin enough to circulate between the bronze bushings and the shaft. NEVER USE A MIXTURE OF CUP GREASE AND CYLINDER OIL FOR THE TRANSMISSION. NEVER USE A SOLID GREASE IN THE TRANSMISSION. NEVER USE GEAR DOPE IN THE TRANSMISSION. USE A FLUID OIL ONLY. "Caterpillar" Transmission Oil has been especially developed for transmissions of "Caterpillar" Tractors and its use is recommended.
- 46 —** Wipe breather cover clean so that dirt will not drop in transmission. Drain oil from transmission at intervals of at least once in 90 days, by means of 2 plugs located on the bottom of the right and left half of the transmission. See paragraph 248. Fill case with kerosene, run gears in neutral for fifteen minutes, drain, and fill with fresh transmission oil.
- 47 —** A full discussion of lubrication is contained in Service Bulletin No. 7, to which the reader is referred.

## CARE OF THE ENGINE

---

### General Care

---

- 48** — The engine must have the correct supply of clean Cylinder Oil at all times. The mechanical oiler must be filled when required and operated to give about two drops per stroke of pump. *The water circulation must be maintained effective at all times.* The engine must operate at the speed indicated on the nameplate in order to secure effective distribution of the oil by the dippers AF shown in Figs. 2 and 3. The bearings on the crankshaft and connecting rods must be “kept up” at all times. NO WASTE OR RAGS GIVING LINT MUST EVER BE USED IN THE CRANKCASE OF AN ENGINE, IT IS SURE TO CLOG THE OILING SYSTEM AND PUMP SCREEN AND DAMAGE WILL RESULT.

### Wipe Crankcase Doors Clean Before Entering

- 49** — *The crankcase doors of the engine must always be wiped clean with a rag or a piece of waste saturated with distillate, before removing to replenish the oil supply or to examine bearings. The operator's sleeves should be brushed off so that no dirt will fall from the clothing into the oil. All wrenches and bars used in the crankcase of the engine must be rinsed with distillate before working on the bearings, thus minimizing the possibilities of putting dirt in the oil.* KEEP THE OIL SUPPLY SCRUPULOUSLY CLEAN—IT PAYS.

### Lubrication

- 50** — The lubrication of the 45 engine is the splash system with circulating pump. The circulating oil pump is shown in Fig. 3 as BE. A mechanical oiler is employed to deliver oil to the bottom of the pistons on the thrust side (not shown on Figs. 2 or 3).

## Adjustment of Oil Levels

- 51 — The oil level is adjusted by means of raising or lowering the overflow pipe Y, Fig. 2. The correct oil level is shown in Fig. 4.
- Except under extreme conditions, the overflow pipes under each cylinder should not be filled with oil, but should show the condition that exists in Fig. 4.
4. An oil level that is too high is shown in Fig. 5.
- Too high an oil level causes undue oil consumption and in addition readily causes trouble by fouling the spark plugs and producing carbon in the combustion chamber.
- 52 — The oil level under each cylinder is independent of the others. From the oil pit under each cylinder, the oil flows through the overflow pipe Y to the tunnel on the bottom of the crankcase, and thence into the oil reservoir AG, Fig. 2.
- 53 — From the oil reservoir AG, the circulating pump BE, Fig. 3, forces the oil to the sight feed distributor AT, Fig. 2, and thence by four distributing pipes to the separate oil pits again, thus maintaining a constant level condition which is taken care of by the overflow pipe. If waste, lint or pieces of carbon clog the oil screen AD, Fig. 2, or the distributor pipes become clogged, the oil level under one or more cylinders may get low and result in damage to the piston and cylinder or bearings. The oil screen AD must be kept clean of all obstruction.

## Clean Oil Pump and Screen

- 54 — The screen AD is placed over the oil pump inlet to prevent the entrance of material that would clog the circulating pump and distributor pipes. Whenever the sight feed oiler AT does not show a continuous flow of oil the screen AD should be examined and cleaned.
- 55 — To clean the oil screen AD, wipe the bottom of the oil reservoir AG clean and free from dirt. Obtain a clean 5-gallon oil can, remove the oil reservoir plate BF, drain and catch the oil that comes out of AG. This will give direct access to the screen AD and cleaning can be effected. If this adjustment has not entirely remedied the condition, it will be necessary to remove the oil reservoir AG and disassemble the pump BE, Fig. 4. This is accomplished by removing the taper pin in the spiral gear AH, Fig. 3. Remove the cap screw on the pump BE, drop it away from the bottom of the crankcase where it can be readily disassembled. In replacing the pump, be sure that the cap screws are set up tight and that the taper pin is replaced in the spiral gear AH firmly, and cotter pin put back securely. In the 45 tractor it will be necessary to drop the cross ties to remove the oil reservoir AG.

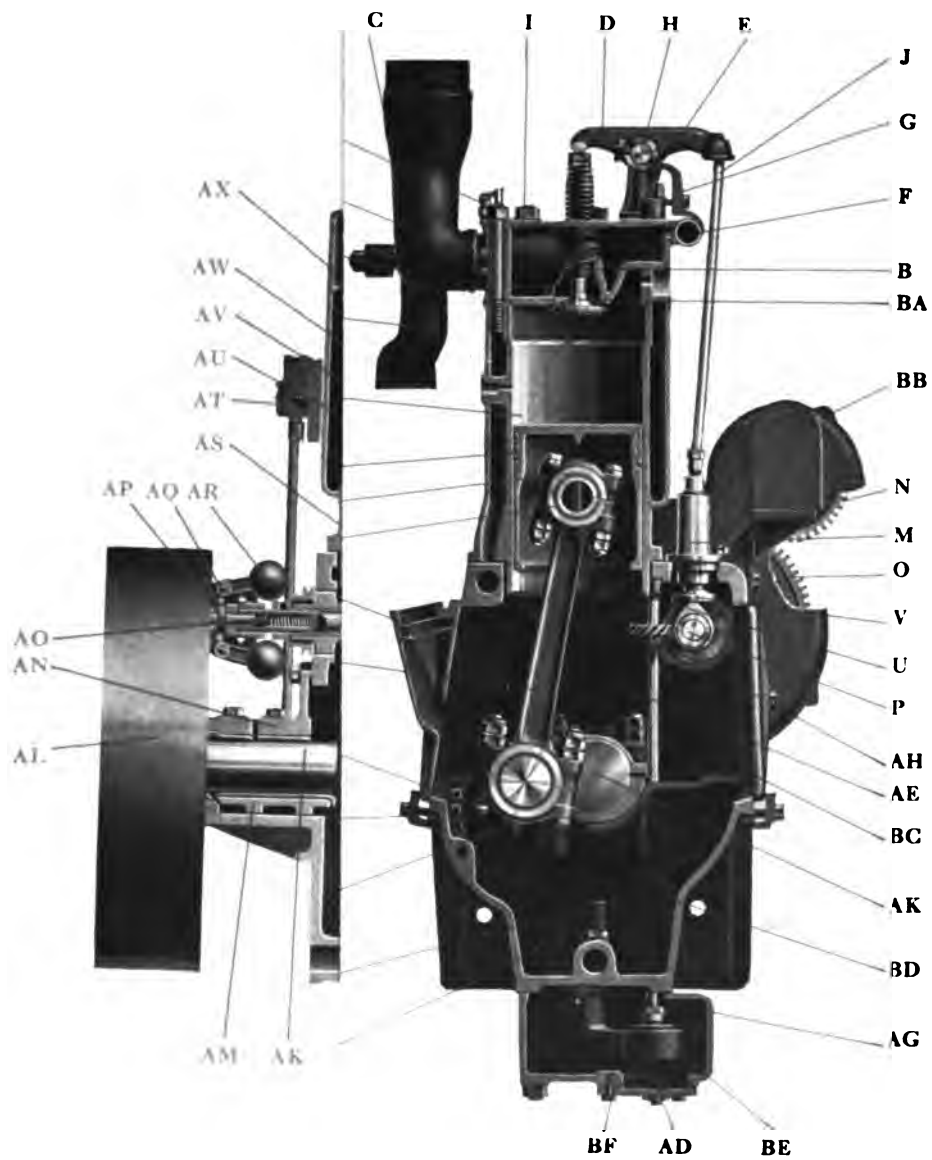

Fig. 3

END VIEW 45 ENGINE

- |   |                             |   |                          |    |                       |
|---|-----------------------------|---|--------------------------|----|-----------------------|
| A | Inlet Valve                 | N | Main Exhaust Valve       | BH | Side Plate Clamp      |
| B | Valve Stem Guide            | O | Crankcase                | BI | Connecting Rod Bolt   |
| C | Exhaust Manifold            | P | Side Plate               | BJ | Oil Filler Side Plate |
| D | Rocker Arm                  | Q | Crankcase                | BK | Inlet Manifold        |
| E | Rocker Arm Bracket          | R | Rotary Oil Pump          | BL | Manifold Clamp        |
| F | Water Outlet Manifold       | S | Oil Reservoir Hand Plate | BM | Cylinder Stud         |
| G | Water Outlet Manifold Clamp | T | Overflow Pipe Lock Nut   | BN | Priming Cup           |
| H | Rocker Arm Pin              | U | Exhaust Valve            |    |                       |
| I | Cylinder Head               | V | Tappett Guide            |    |                       |
| J | Valve Rod                   | W | Inlet Valve              |    |                       |
| K | Cylinder                    | X | Cylinder                 |    |                       |
| L | Tappett Guide Clamp         | Y | Overflow Pipe            |    |                       |
| M | Tappett Guide               | Z | Crankcase                |    |                       |





---

“CATERPILLAR” 45 TRACTOR

---

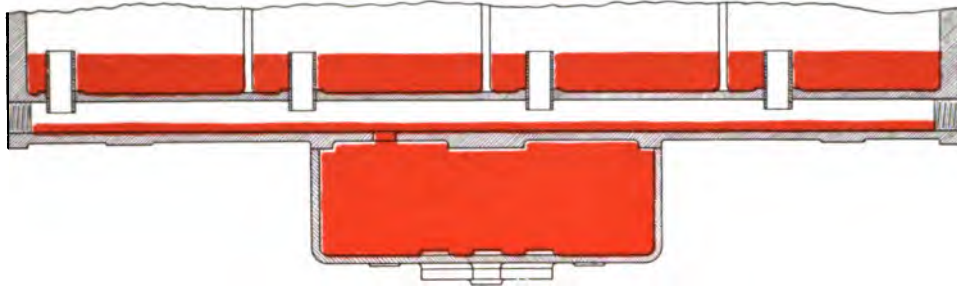

**Fig. 4. Correct Oil Level.**

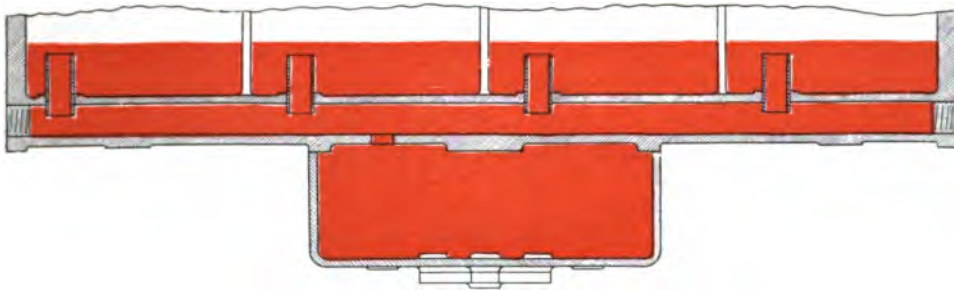

**Fig. 5. Oil Level Too High.**

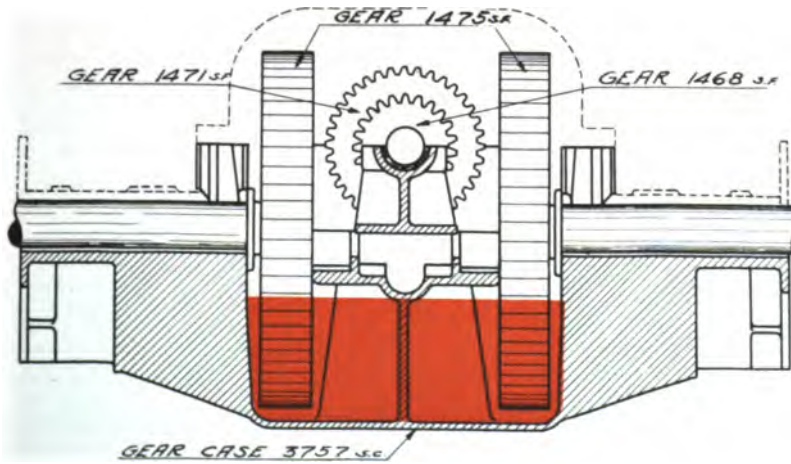

**Fig. 42a. Correct Oil Level for 45 Transmission.**

(See paragraph 251, page 82.)

## Examine the Oil Supply

- 56 — The condition of the oil supply should be examined daily. This can be accomplished when trying the bearings. When the engine is in operation, the finely divided particles of carbon that are in the oil film on the cylinder walls have an opportunity to work back into the crankcase oil supply. Leaky piston rings or over-rich mixtures may result in fuel particles finding their way into the crankcase oil. In addition, the oil splashing against the hot underside of the piston will char and after a while build up an accumulation of carbon. Contraction and expansion will loosen particles of this material and they drop into the oil level. There is no oil that will not char under the piston head and this point must be watched.
- 57 — **IMPORTANT:** The hand should be put into the oil level to feel the condition of the oil. The oil should feel "velvety" and should not contain any grit in the bottom of the crankcase. If the oil feels harsh and if a "sludge" is present in the bottom of the oil pit, the crankcase should be drained and washed with kerosene and new oil put in. See paragraph 58 for correct method of washing crankcase. The oil that is drained from the engine can be caught, allowed to settle and used to good advantage on the first motion chains. **Never replace used oil in a crankcase.**

## Wash the Crankcase of the Engine

- 58 — On the carbureter side of the engine and opposite each oil pit a drain plug is provided. Drain plugs are also provided in the oil reservoir AG. Remove the drain plugs, catch the oil. Because of the oil tunnel on the bottom of the crankcase, the removal of the final quantity from the pits must be effected by hand. Remove plate BF on bottom of oil reservoir AG, Fig 3, and clean bottom of oil reservoir by hand. Replace BF, replace plugs in crankcase, *fill each compartment with kerosene* till oil level is reached. Pour an extra gallon in one compartment so that the oil reservoir AG will receive enough so that the oil pump BE will pump the kerosene and clean out the supply line and the distributor pipes from the sight feed AT. Replace crankcase doors and start the engine, **ALLOW IT TO RUN FOR TEN SECONDS**, being careful never to exceed this time. Remove plugs in crankcase and oil reservoir, drain off kerosene, allow engine to stand for a while, then wipe oil pits clean with a cloth that does not give off lint. **AFTER WASHING CRANKCASE, FILL WITH CLEAN CYLINDER OIL.** *Time devoted to keeping the oil clean and washing the crankcase when required pays big dividends in freedom from bearing trouble and loss of time due to impaired lubrication.*
- 59 — **CAUTION.** *Never use distillate* to wash the crankcase; kerosene is the proper agent.
- 60 — A full discussion of Lubrication is contained in Service Bulletin No. 7.

## Bearings

- 61** — *The bearings of an engine should be tested when the engine is hot. The operating temperature has then expanded the various parts and the oil film is thinned to the condition under which it has to work. A bearing tested when the engine is cold can have a good deal of play taken up by the thickened oil film and an accurate determination cannot be made.*

All bearings in a ‘‘Caterpillar’’ engine are made from armature metal made to specification.

- 62** — *Wipe crankcase doors clean before removing, rinse the bar with which the bearings are to be tried with distillate. Don't deliberately put dirt in the crankcase by careless methods.*

### To Determine a Loose Crankshaft Bearing

- 63** — *Insert a heavy pinch bar under the crankshaft close to the bearing to be tried, and, using the crankcase as a fulcrum, try to move the crankshaft vertically in its bearing by prying. One hand should be on the bearing to detect motion, while using the other to operate the bar. The least movement in the bearing can be felt. Sometimes the movement is so great that it can be seen. The time to prevent any damage and make the bearing adjustment is when the movement can be felt only. Progressively bad is when the movement in the bearing can be seen, and the worst condition of all is when the movement can be heard as a knock.*

### To Determine a Loose Crank Pin Bearing

- 64** — *The crankpin bearing in agricultural practice is commonly called the connecting rod bearing. To determine any looseness, turn the engine over with the fly wheel till the crankpins of Nos. 1 and 4 connecting rods are close to the crankcase door. Place the bar under the bearing, using the crankcase as a fulcrum. One hand should be partly on the web of the crankshaft and partly on the crankpin bearing. There should be absolutely no vertical movement. Repeat for Nos. 2 and 3. This bearing should be able to move sideways, however, about  $\frac{1}{8}$ ”.*

### To Determine a Loose Wrist Pin Bearing

- 65** — *The wrist pin bearing, also called the piston pin bearing, is a bronze bushing open on one side that fits over the piston pin and is clamped inside the cap that fits over the upper end of the connecting rod. The bronze bushing ZH90, in Fig. 6, is prevented from turning by the shim, M9494, that fits in the open side of the bronze bushing. The upper end of the connecting rod assembly can move sideways on the piston pin about  $\frac{1}{8}$  inch. If the crank end of the connecting rod bearing is properly cared for, there will be but little trouble with the wrist pin bearing.*

---

## CARE AND OPERATION

---

- 66 — Fig. 6 shows a connecting rod assembly for the 45 engine.

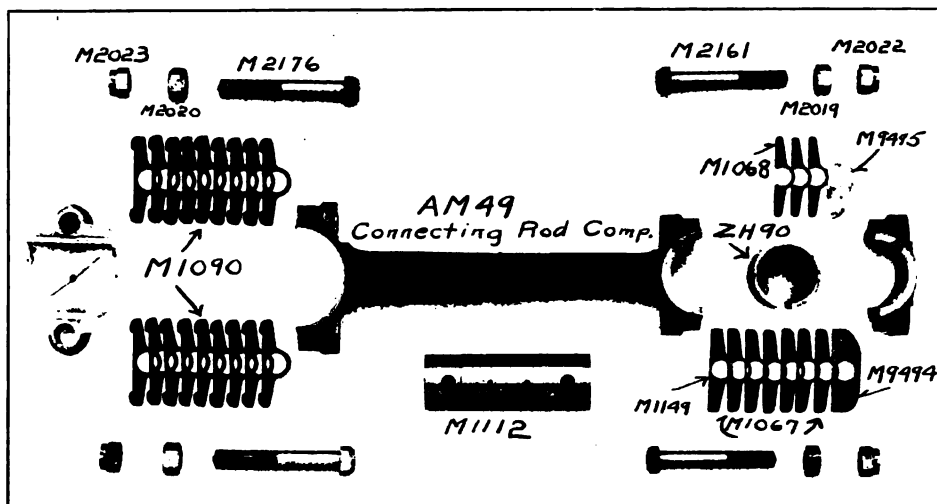

Fig. 6

- 67 — To determine if there is any looseness in the wrist pin bearing, two methods can be used.

First method: Revolve the crankshaft by the fly wheel until the desired piston is at its greatest down position. With a light bar get a "purchase" on the camshaft and under the piston. With one hand on the connecting rod and a thumb extending to the piston, any movement can be felt. *Do not confuse the wrist pin bearing with the crank pin bearing looseness.*

Second method: The best way, however, to determine looseness in the wrist pin bearing is to remove the pistons and connecting rods from the cylinder, wash the underside of the piston with kerosene, set piston on head and attempt to *rock the connecting rod sideways.*

- 68 — If it is necessary to take up wear in the wrist pin bearing, remove the wrist pin, M1112, from the piston. Remove the cap on the connecting rod and remove shims on both sides until the desired amount of play is taken up. In this wrist pin adjustment, as with the others, extreme care should be taken that the bearing is not too tight.
- 69 — *If much adjustment is required on the wrist pin bushing, it will be necessary to ream it before a perfect fit on the piston pin can be secured, because of the fact that the bushing is open on one side only, and closing it up will make the inner diameter of the bushing out of round.* If the oil supply has been kept clean from grit and dirt and care taken in keeping the lower connecting rod bearing in adjustment, there will be but very little need for making a wrist pin adjustment.

### Removal of Shims or Liners

- 70 — The standard thickness of a shim or liner in the "Caterpillar" engine is .012 (twelve thousandths) of an inch, or approximately three times

the thickness of the paper that this Care and Operation Book is printed on. *When a bearing is loose and requires the removal of a shim to take up the wear, do not remove one shim from one side of the bearing only, but a shim from each side of the bearing.* If a shim is removed from each side of a bearing, the adjustment of the wearing surfaces of the babbitt bearing and the shaft is not altered.

- 71** — Most connecting rod bearings contain one thin shim .005 (five thousandths) of an inch for close adjustment. When wear occurs and this shim has to be removed, preserve it for future adjustment. In the removal of a standard shim, twelve thousandths of an inch thick, the distance may prove too great. In this case, cut a couple of shims from a good grade of wrapping paper and, together with the five thousandths shim, a good adjustment can be secured.

### **Dirt Causes Most Bearing Trouble**

- 72** — *If the lower connecting rod or crank pin bearings and the crankshaft bearings require frequent adjustment, it indicates that some cutting compound is at work and is a direct indictment against the engineer for the lack of correct care of his crankcase oil supply. It indicates one of two things: Either that some cutting compound is at work, such as grit and dirt in the oil, or that the oil is of poor body. The oil may have been good quality at first, but thinned by the entrance of fuel past the piston rings.* ALWAYS WIPE CRANKCASE DOORS CLEAN BEFORE ENTERING CRANKCASE. BE SURE THAT TOOLS USED ON THE BEARINGS ARE SCRUPULOUSLY CLEAN.

### **What is a Knock**

- 73** — Bearing surfaces at working temperature should be separated by only such space as is sufficient to contain the necessary oil film. The oil film then absorbs the movement smoothly and keeps the metallic surfaces apart. If the bearing is loose, however, the force of the movement is so great that the oil film is broken through and metallic contact of the parts ensues. *A knock will develop rapidly and will result in the failure of the bearing, and produces shock and vibration in the parts affected.*

### **Crystallization or Fatigue**

- 74** — Iron or steel which has repeatedly been overstrained by shocks, such as are produced by knocks, becomes brittle and breaks with an apparently crystalline fracture. The part is then said to have become *crystallized*. A knock in the bearing produces shock and vibration on the web or bearings of the crankshaft. A break from crystallization has a very smooth, glass-like surface, while a direct failure of the metal from a defect will show a sharp, rough surface. WATCH BEARINGS SO THAT KNOCKS WILL NEVER BE PRODUCED.

## Crankshaft

- 75 — The crankshaft is made of a special grade of alloy steel, drop forged, heat treated, and contains five bearings, with all bearings ground accurately to size. The end of the crankshaft over which the large flywheel fits contains an SKF No. 1207 ball bearing race on which bearing the master clutch member 1629SC works, as shown in Fig. 36, page 75.

## Crankshaft Bearings

- 76 — The crankshaft is supported by five bearings. The bearing at the end of the crankcase next to the large flywheel is called *the flywheel end crankshaft bearing*, while the bearing on the other end of the crankcase is called *the gear case end crankshaft bearing*. The three bearings between the two outside bearings are termed the middle bearings. In the Price List of Parts *the bottom half is called the bearing and the top half is called the bearing cap*. The cap for the flywheel and gear case end in addition has a plate cast on to completely cover the area of the crankcase required to insert the crankshaft through; consequently, these two are called flywheel cap and end plate and gear end cap and end plate. All crankshaft bearings are babbitted with Armature Metal made to specifications.

## Bedding the Crankshaft

- 77 — If the crankshaft bearings have been rebabbitted, or if it has been necessary to true up the crankshaft and it is necessary to scrape in the bearings in the field, proceed as follows: Insert the bottom half of the flywheel and gear case end bearings and the bearing in the middle of the crankcase. Blue the crankshaft with a thin film of Prussian Blue or Lampblack (these colors can be obtained in collapsible tubes from any hardware store) and rotate the crankshaft in the bearings. The high spots on the bearings will have a deposit of color left on them. Remove the bearings and scrape with a large babbitt scraper to remove the high spots. After these three bearings have been fairly well scraped into line, insert the two remaining bottom halves of middle bearings, blue shaft and repeat the spotting and scraping until all the bottom bearings are in line and show nearly solid color when the crankshaft is rotated. *This bedding operation has to be accurately done, as all the strains are transmitted to the bottom bearing, and if one bearing is lower than another it will put a weave and strain on the crankshaft, which will start crystallization and ultimately result in a broken crankshaft.*

## Fitting Caps to Bearings

- 78 — After the bottom bearings have been fitted, put the bearing bolts into place. Blue the crankshaft, insert 7 to 9 shims on each side of the

bearings and fit each cap separately. Scrape the cap as outlined above until the bearing surface throughout shows practically a solid color. *Slack off the bearing cap when fitted and proceed to the next cap.* Slack off the caps as they are fitted so that determination can be made by revolving the crankshaft for the particular cap that is being worked on if the fit is too snug. When the bearing caps are all in line, with the high spots removed, the final fit is then a matter of inserting shims. Always be sure to have an equal number of shims on each side of a bearing. The operation of fitting the bearing by color is termed "spotting the crankshaft."

### Relieve Sides of Bearings

- 79 — Babbitt on the sides of both the bearing and the cap where the shims meet should be "relieved," that is, scraped away, so that when the bearing is bolted tightly into place it will not pinch the shaft, at the edge where the two bearings meet. *The shims should not project far enough in the bearing to rub on the crankshaft. These precautions must be taken on the connecting rod bearings as well.*

### Fitting Connecting Rod Bearings

- 80 — Remove the spark plug in the cylinder to release compression, blue the crankshaft with a thin film of color, insert piston in the cylinder, mount the upper half of the connecting rod bearing on the crank pin, revolve crankshaft. When the upper half has been accurately spotted and scraped, place an equal number of shims on each side of the bearing and bring the lower half of the bearing into place by tightening on the connecting rod nuts, and fit cap by spotting and scraping.

**NOTE.**—*One side of each connecting rod and cap contains the same figure on the upper and lower half, as*

1	2	3	4
1	2	3	4

*Always have these same numbers on the same side, as the lower*

*part of the bearing will match in the way that it was sawed from the original drop forging, and the connecting rod bolt holes will always line up. When one connecting rod bearing has been satisfactorily scraped in and bolted to the final fit, slack off on the connecting rod bolts and proceed to the next connecting rod. It is not possible to scrape a connecting rod bearing properly without having the piston in the cylinder, as the bearing must be scraped so that the piston will be square in cylinder. When bearings are sent to the factory for rebabbiting, they are reamed approximately to size, thus obviating the necessity of any great amount of scraping.*

### To Make a Babbitt Scraper

- 81 — The best scraper for crankshaft and connecting rod bearings can be made out of a large mill file which has been hollow ground on one side, one edge brought to a straight edge and a small hollow grinding placed on the thin edge to make a rapid cutting tool. A file is made of very hard material and the grinding is a little difficult, but nearly every machinist is familiar with this type of babbitt scraper and can make one.

In using the scraper on the bearing, take a light, firm cut from one side of the bearing to the other.



## To Test for Loose Bearings

- 82 — Refer to paragraphs 63 and 64 for the correct method of determining loose bearings on the crankshaft. If it is not possible to maintain an adjustment on a connecting rod or crankshaft bearing, it indicates that there is grit present in the oil which is wearing down the babbitt surface rapidly, or else that the crankshaft is out of round due to allowing bearings to pound and knock.

## Knocks

- 83 — Every engine has a certain characteristic noise of operation with which the operator in time becomes familiar, and he can detect immediately if anything is wrong with the engine by the odd noise that it makes. Any noise that is not common to the engine is spoken of as a knock, and may be due to several causes. Knocks can be divided roughly into the following classifications:

1. Bearings being loose.
2. To magneto being timed too early.
3. Combustion chamber full of carbon, giving pre-ignition, irrespective of correct timing of magneto.
4. Knocks or "pinging" which occur only when engine is on hard spots or up against sudden overloads and cease when normal load conditions prevail.

The following brief discussion is presented to aid the operator in determining and remedying some of the above classifications of knocks.

- 84 — 1. Bearing surfaces should be separated only by such a space as is sufficient to contain the necessary oil film to cushion and absorb the power stroke, thus giving a smooth operating engine. When the engine leaves the factory this space is properly adjusted on crankshaft and connecting rod bearings, but in due course of time the softer metals which constitute the surface of the bearing become bedded down, and when reversals in pressure occur as the engine is operated, together with a slight amount of grit or dirt that may come from carbon in the oil or from the introduction of foreign material into the crankcase by the operator, the babbitt will be worn away and the bearings and the shaft are likely to be separated by a distance so great that the oil film cannot absorb the shock without being broken. *A knock occurs when the distance that the shaft can move in a bearing is so great that the force applied through the distance traveled will break through the oil film and allow metal-to-metal contact of the babbitted bearing and the steel crankshaft instead of the oil film cushioning and absorbing the blows.* Small hammering blows or

knocks will result, and these will damage a bearing and a crankshaft far more rapidly than any amount of continuous and direct pressure. A BABBITTED BEARING WILL STAND ALMOST ANY AMOUNT OF SQUEEZING, BUT THE MOMENT THAT A KNOCK OCCURS IT COMMENCES TO FAIL IN PERFORMING ITS FUNCTION. A KNOCK DEVELOPS EXTREMELY RAPIDLY, CAUSING A FAILURE OF THE BEARING.

- 85** — 2. If the magneto is timed too early, or if the spark is advanced too far, the compressed charge will be ignited at such a point ahead of the travel of the piston towards the top center *that the force will be downward on the connecting rod ahead of the time when it should be, thus producing a knock even though the bearings throughout are tight.* This knock has a very characteristic sound.

If the knock occurs when the magneto is correctly timed, it indicates that the spark has been advanced too far. To remedy this knock, retard the spark to the point where the knock does not occur. The correct point for the magneto to fire is as follows: The piston on top center, circuit breaker full retarded, the points in the circuit breaker should just commence to separate. If any of these conditions varies, the adjustment should be made. See paragraph 180, page 52, for a complete discussion of timing the magneto.

If the knock is due to the magneto being timed too early, the magneto will have to be retimed.

- 86** — 3. If the combustion chamber is full of carbon, the heat of combustion will make projecting particles of the carbon glow, and when the incoming gases have been admitted and compression begins, *the mixture will ignite by the heat of compression and the glowing particles of carbon ahead of the time when the magneto would normally ignite the charge if correctly timed, thus producing a severe knock.* The remedy, of course, is to clean the combustion chamber of carbon. This may be satisfactorily accomplished by removing the cylinder head and scraping.

- 87** — 4. An engine may pull its load as in plowing without any knocks or ‘‘pinging’’, but when it reaches a certain hard spot in the field it may ‘‘ping’’ and possibly lose power till the point is passed. This indicates that for normal work the carbureter setting is correct, but that for the peak load there is not enough fuel in the mixture to give the engine the proper power when on the hard pull. This pinging noise or knock can be remedied by giving the carbureter more fuel. It may not be possible to set the engine so that pinging will not occur on the hard spots without having the mixture over-rich for the balance of the work. If this condition occurs the operator, of course, will have to use his judgment in the best setting of the carbureter.

## Other Knocks

- 88 — The knocks enumerated above can occur without the engine overheating, unless operated for a long time continuously with the condition existing. There are other types of knocks that exist in an engine when overheating condition occurs, to which knocks are incident in operation. For instance, the camshaft can be out of time by either being set early or late and the valve rods can operate improperly by causing the valve to open or close incorrectly. Of course, the remedy for all these types of knocks is to remove the source that is causing the engine to overheat, and is taken up in detail in paragraph 224, page 67, and in Service Bulletin No. 8.

## What Damage Does a Knock Do?

- 89 — A knock in the bearing puts undue strains on the crankshaft and sets up shock and vibration. Vibration in the crankshaft produces crystallization, and the crankshaft will ultimately break.

## Remedy Knocks Immediately

- 90 — A babbitted bearing will stand any amount of direct and continuous pressure without failing as long as lubrication occurs. When knocks exist, however, the trouble will develop rapidly and failure of the bearing will result. Remedy all knocks when they are first detected.

## Running with One or More Cylinders "Missing"

- 91 — *Severe punishment is given the crankshaft whenever an operator drives the engine for any length of time with one or more cylinders "missing."* This causes the engine to run out of balance and sets up a great number of vibrations in the crankshaft, which does extreme damage to bearings and overstrains the crankshaft, tending to produce crystallization. In addition, running with one or more cylinders "missing" allows the oil film on the cylinder wall to be thinned by the fuel particles, and these fuel particles will ultimately find their way into the crankcase, thinning the crankcase oil supply and doing a great deal of injury to the lubricating oil. *The most damage, however, is done to the crankshaft, and the condition should be remedied immediately.*

## Cylinders

- 92 — The cylinders are made of close-grained cast iron, from a special mixture. The top and bottom of the cylinder are machined at one operation, thus making these parts absolutely parallel. The cylinder is then reamed and finished by grinding to a smooth surface. The ground surface of the finished cylinder is not allowed to vary more than .001 (one thousandth) of an inch from a standard diameter.

## Water Jackets

- 93** — The water jackets of the cylinders must be kept free from accumulation of sediment and scale at all times, in order not to impede the transfer of heat to the circulating water. In some localities it may be necessary to use water from sloughs or open ditches for a while, but the operator should keep a close watch, and, if sediment accumulates, the water jackets should be cleaned out. Each cylinder contains a drain plug on the magneto side of the engine, which plug can be removed and a partial examination made of the water jacket. The best way to examine a water jacket is to insert a small iron rod through the circulation ports at the top of the cylinder when the cylinder heads are removed, and scrape around the bottom of the water jacket. *If sediment or scale is present, the cylinder should be removed from the crankcase and the water jacket thoroughly scraped and flushed out.* If scale is present the circulation system should be treated with common washing soda, as outlined in paragraph 225, page 69. Before replacing the cylinder examine the water intake passage at the bottom of the cylinder and scrape clean of any scale or rust. *Be sure in replacing cylinder that the rubber gasket that makes a water-tight connection between the crankcase and the cylinder is in perfect condition and has not slipped when placing the cylinder on the crankcase.* Observation has shown that operators do not give sufficient attention to sediment in the water jackets and the accurate placing of the rubber gasket. Fig. 7 shows a cut-away view of the cylinder and cylinder head and water jackets. This illustration does not show the drain plug at the bottom of the water jacket.

## Keep Dirt Out of Cylinders

- 94** — A dry-air cleaning device is standard equipment with all “Caterpillar” Tractors and must be used at all times. The dry air cleaner is used between the hot air stove and the air intake of the carbureter. This dry air cleaner does not employ moisture in any form, but depends upon air velocities which are set up within the cleaner by passing the air through in a certain direction and centrifugal force throwing the dust to the container walls to clean the air before passing it into the carbureter and combustion chamber.
- 95** — Field or road dust gaining admission to the combustion chamber wears the cylinder out of round, and produces extreme wear on the piston and piston rings. The dirt that comes into the combustion chamber through the carbureter becomes imbedded in part in the oil film and makes a very fast cutting agent. Field and road dust, together with iron particles that have been worn off the cylinder walls and piston rings, is confused as part of carbon. See Service

---

## CARE AND OPERATION

---

Bulletin No. 6, page 8, which shows the field and road dust and ferric oxide content in the analysis of four typical cases of carbon trouble in which the dry air cleaner was not used.

- 96 — A glass jar is placed at the bottom of the dry air cleaner so that the operator can watch the accumulation of dirt. When nearly full the jar should be emptied.

CAUTION—DO NOT EMPTY JAR WHEN ENGINE IS RUNNING. DO NOT FILL DRY AIR CLEANER JAR WITH WATER.

### Keep Cylinders Tight on Crankcase

- 97 — The cylinders must be kept securely bolted to the crankcase. The fit of the bottom of the cylinder on the crankcase should be square and no oil should leak at the joint where cylinder and crankcase meet. If oil leaks between cylinder and crankcase, remove cylinder, clean top of crankcase, cut a gasket out of heavy wrapping paper, shellac top of crankcase, apply gasket, shellac the gasket, allow to get fairly dry, and then put cylinder in place and bolt down.

### Cylinder Head Gasket Must Not Leak Water

- 98 — The joint between the cylinder and the cylinder head is made water-tight by using a copper-asbestos cylinder head gasket. If the cylinder head has not been bolted evenly and tightly into place, the cylinder head gasket may leak water into the cylinder, or the water may leak on the outside of the engine. *To determine if gasket is leaking due to cylinder head being improperly bolted down, proceed as follows:* Slack off the nuts on the cylinder studs a few turns, seat cylinder head on gasket by



Fig. 7

Cut-away view of cylinder, cylinder heads and water jacket.

using a large hammer and a block of wood on cylinder head to cushion blows, *then commence to bring cylinder head into place with the nuts on the cylinder studs by giving each nut in rotation around the cylinder head the same amount of turn until firmly bolted down.* If the cylinder head gasket still leaks, remove cylinder head and remove cylinder head gasket. Dry the top edge of the cylinder and both sides of the cylinder head gasket and shellac and bolt into place. This practice is not to be recommended, but to be used only in case of an emergency repair. If a cylinder head gasket has been used and leaks after being removed, it is better to put a new one in its place.

- 99 — Do not operate an engine when a cylinder head gasket leaks into the cylinder. This is readily determined by the presence of free water in the exhaust. A supply of water such as given by a leaky cylinder head gasket may cause the exhaust valve to warp badly or pit deeply in one place; in addition, water running down inside the cylinder wall may act on the lubrication film, and scoring of the piston and cylinder may result.

### Scoring of Cylinders and Pistons

- 100 — Scoring of cylinders and pistons can be divided into three general classifications:

- 1st. Lack of efficient lubrication.
- 2nd. Failure of circulation system.
- 3rd. Mechanical causes.

These classifications in turn can be divided into:

- 101 — 1st. Scoring of cylinder and piston due to lack of efficient lubrication can be divided into:

*a. Poor-bodied oil*—oil not suited for engine. If oil is too thin, the oil film on the cylinder wall will be destroyed by heat of explosion. Too heavy oil—if piston rings are a good fit and cylinder is not worn out of round, too heavy an oil will not reach top piston ring and piston head in sufficient quantity to prevent scoring.

*b. Oil level too low.* Operator may not have put sufficient oil supply into oil reservoir. Rotary pump or screen clogged. Distributor pipe to particular oil pit under cylinder from sight feed may be clogged. Overflow pipes improperly adjusted. Shims removed from connecting rod bearing without readjusting oil level so that dippers on end of connecting rod dip into oil level  $\frac{1}{8}$  of an inch.

*c. Dirty oil.* Oil may be fouled with carbon and grit, or by entrance of fuel particles to crankcase oil supply. Crankcase should be drained and washed out with kerosene at such time as daily examination by hand of condition of oil in bottom of crankcase indicates

---

## CARE AND OPERATION

---

presence of dirt and grit. Fuel particles gaining admission past poorly-fitting piston rings or running engine continuously with one or more cylinders "missing" will break down the oil body. See paragraph 58, page 14, for correct method of washing crankcase.

*d. Running engine below 600 revolutions per minute.* Cylinders, pistons, camshaft and crankshaft bearings depend upon the splash produced by the dippers on the end of the connecting rod throwing the oil to lubricate the parts. If engine is operated a great deal below correct speed, oil will not be splashed properly to reach parts intended.

102 — 2nd. Scoring of cylinders and pistons due to failure of circulation may be divided into:

*a. Pump and fan belt slipping.* Belt improperly laced to be dependable in operation. Presence of oil or water on belt, causing it to slip. Belt may be too long so that idler will not take up sufficient slack. The centrifugal pump has to be positively driven at all times to circulate the water and keep temperature of cylinders at point of safety.

*b. Brass glands on pump may admit air to pump.* Packing inside of glands may be worn out and require replacing to exclude air.

*c. Pump shaft may have end play, or bushings worn out, thus interfering with circulation.*

*d. Circulation may be impeded.* Rubber particles may become disengaged from hose connections. Gaskets where crankcase inlet water manifold joins bottom of inlet to water jacket in cylinders may be improperly placed. Water jackets may contain large deposit of sediment due to using dirty water. Scale may be present in water jackets and radiator tubes.

*e. Engine below speed.* If engine is operated much below 600 revolutions per minute under load, the pump may not be driven fast enough to circulate water sufficiently to remove heat generated.

Do not "idle" engine for long periods. This is a prolific source of scoring.

103 — 3rd. Mechanical causes of scoring can be divided into:

*a. Particles of carbon becoming disengaged from the side of a stuck piston ring. Piston ring stuck with carbon.*

*b. Piston ring breaking at lap, due to improper fitting of ring and lack of provision for expansion. See paragraph 120, page 33, for correct fitting of piston ring. Broken lap will work under piston ring and produce undue pressure of part of ring against cylinder wall in one spot.*

*c. Wrist pin getting loose on its seat. Operator may have been careless in getting wrist pin set screw properly seated. Set screw may shear and score cylinder.*

*d. Valve grinding compound may find its way into cylinder, due to improper cleaning of cylinder head after grinding valves.*

- e. Forcing wrist pin to seat, distorting shape of piston.
- f. Idling engine under full load carbureter adjustment too long a time. If engine is to be idling for a long time, needle valve should be adjusted for low speed. **THIS IS IMPORTANT.**

## Reboring Cylinders

- 104** — If cylinders have been scored or worn out of round, they may be rebored and a new set of oversize pistons fitted if the final diameter required to clean cylinders up is within the outside limit set by the factory for reboring.
- 105** — *It is not good practice to rebore only one cylinder and use this one with the three remaining ones, as it will put the engine out of balance and put a severe strain on the crankshaft.* If reboring is required, send all four cylinders to the factory, *together with the wrist pins and the connecting rods.* If wrist pins are fitted to the pistons in the field, the piston may be knocked out of round by forcing the wrist pin to its final seat. When the connecting rods are returned with the cylinders and wrist pins, the wrist pin bearing can be fitted accurately if it requires adjusting.

## Instructions for Assembling Rebored Cylinders

- 106** —
  1. After assembling pistons on wrist pins and connecting rods, test them for alignment by holding a steel square on top of crankcase with one edge of square against piston “skirt.” These should be a clearance of about .006 (six thousandths) of an inch between the square and piston “head” edge when the square is touching the “skirt” edge. When pistons are seriously out of line, they must be straightened. This usually can be done by scraping babbitt in crank-pin bearing. Always try lower connecting rod bearing bolted down, so that bearing will float sideways on crank pin when piston is in cylinder. **THIS IS IMPORTANT.**
  2. Whenever it is necessary to assemble pistons to connecting rods in the field, great care should be taken not to distort pistons while driving in wrist pins and while tightening set screws. Wrist pins should be a snug fit, but it should be possible with a very light drive to set it in position.
  3. Inspect pistons very carefully (outside and inside) to make sure that they are absolutely clean. It is equally important that cylinders, cylinder heads and gas passages *be absolutely clean.* When cylinders have been installed and cleaned, remove piston rings from piston (keeping in mind the proper order in which to return them) and wash thoroughly in kerosene and wipe with a clean cloth. Wash rings in kerosene and wipe with cloth. **IT IS IMPORTANT NOT TO BUILD ANY DIRT INTO ENGINE WHEN A REBORED**



---

## CARE AND OPERATION

---

JOB HAS TO BE ASSEMBLED IN THE FIELD. Wash cylinder with kerosene, wipe dry.

4. Just before slipping pistons into cylinders, put a generous supply of clean oil over sides of piston and over piston rings.
5. **START ENGINE WITH NO LOAD, AND RUN LIGHT FOR AT LEAST THREE HOURS.** Load can gradually be applied, but "feel" temperatures of cylinders occasionally. If one cylinder shows a tendency to heat more than others, make sure of oil level and "run engine in" a little longer at no load, increasing load as heating decreases. **UNDER NO CIRCUMSTANCES SHOULD A HEAVY LOAD BE PUT ON ENGINE IMMEDIATELY AFTER ASSEMBLING, WITHOUT THE ABOVE CAREFUL "RUNNING IN" OF THE ENGINE.**

### Pistons

- 107** — The piston, together with its attached piston rings, is one of the most important members of the internal combustion engine, for upon the proper working of these parts depends to a greater or less degree the power developed by the engine, as well as its successful operation.
- 108** — The piston must maintain gas tightness in the cylinder to perform the functions of:
- a. Drawing in of the fuel vapor.
  - b. Compressing the charge.
  - c. Transferring with as little loss as possible the pressure of the expanding gases.
  - d. Exhausting the burned gases.

When an internal combustion engine is in operation, it is estimated that the temperature of the ignited and compressed fuel vapors during the first part of the stroke is about 2700 degrees Fahrenheit. The head of the piston is directly exposed to this temperature for a small fraction of time every second revolution, and a part of the heat given to the piston head is gradually transferred to the piston skirt. The rest of the heat is transferred to the cylinder walls and thence to the water jackets, and part is exhausted through the exhaust valve. The temperature of the piston skirt increases about 300 degrees above normal temperature under work. Due to this increase of temperature and the expansion attendant on it, other means are devised to have the piston maintain gas tightness in the cylinders.

### Shape of Pistons

- 109** — The piston itself cannot be made an absolute fit in the cylinder because provision has to be made to take care of the expansion under the high operating temperatures to which it is subjected.

The expansion of the piston is taken care of in two ways:

- a. The piston is tapered from the bottom of the third ring to the top of the piston.
- b. The body of the piston or “skirt” is made a certain amount smaller than the cylinder it works in.

Fig. 8 shows the shape and taper of the piston. Fig. 9 shows a cross-section of the piston.

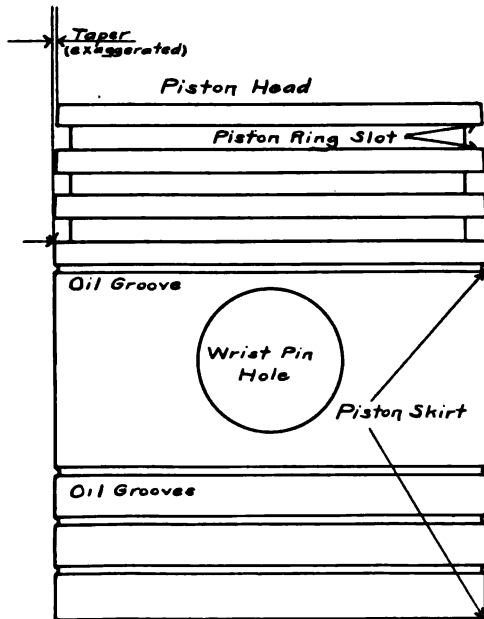

**Fig. 8. Shape of Piston.**

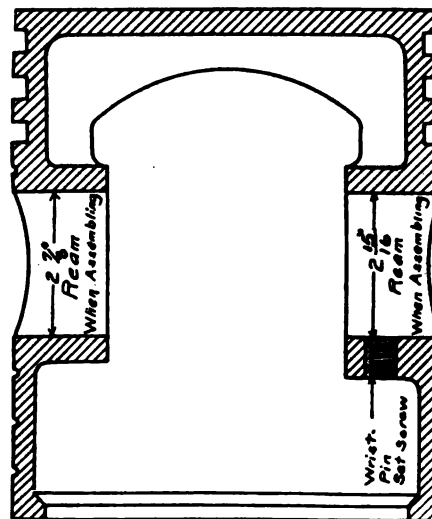

**Fig. 9. Cross-section of Piston.**

The sides of the piston body or skirt are parallel. When the working temperatures expand the piston, it finally fits the cylinder with a sliding fit. The film of lubricating oil occupies the clearances between the piston and cylinder wall, and is the final seal to retain compression.

## Oil Grooves

- 110** — At the bottom of the third piston ring slot and on the bottom of the piston skirt, oil grooves are cut to carry the lubrication oil up the cylinder walls and to the piston rings. Always keep these oil grooves clean and free from accumulation of carbon.

## Wrist Pin Hole

- 111** — The wrist pin hole is bored at right angles to the axis of the piston through two bosses. The hole in the boss that carries the wrist pin set screw is reamed to 2 15/16 inches, while the hole in the other boss is reamed to 2 7/8 inches.

## Wrist Pin

- 112** — The wrist pin is made of steel and is case hardened. The end of the wrist pin that carries the hole for the wrist pin set screw is smaller than the blank end and must be inserted through the hole in the piston opposite the boss carrying the wrist pin set screw when but one set screw is used. In fitting new pistons to wrist pins there is always a chance that the operator in the field may get the piston out of round by forcing the wrist pin in the piston. For this reason it is always advisable to return the connecting rods and wrist pins to the factory when new pistons are to be fitted.

## Fitting the Wrist Pin

- 113** — *The wrist pin should seat with a tapping fit.* Use a lead hammer and a hardwood block in seating the wrist pin. *Do not strike hard blows on the wrist pin.* It is possible to knock the piston out of round several thousandths of an inch if the wrist pin is forced.

## Wrist Pin Set Screw

- 114** — The wrist pin is held in position by one wrist pin set screw. This allows the expansion of the case-hardened steel wrist pin to occur without carrying the piston out of round, as but one end is anchored. The wrist pin set screw should be kept tightly and accurately in its position.

## Piston Ring Slots

- 115** — Piston ring slots are accurately cut at right angles to the axis of the piston and are not allowed to vary more than .001 (one thousandth) of an inch in width. *A file must never be used on the piston ring slots to secure the fit of piston rings.* Do all work on the piston rings. See paragraphs 120-126 for cleaning slot and fitting piston rings.
- 116** — Great care should be exercised so that loose piston rings are not allowed to wear the square faces of the piston slot to a bevel. If these square edges are worn to a bevel, it will be impossible to prevent the passage of gases above, behind and below the piston ring and the edges of the slot. When the piston ring is inserted on the piston, it should be free to move horizontally in the slot, but the vertical movement should not be much greater than .001 (one thousandths) of an inch. When the piston ring expands, it will just about close this clearance in the piston ring slot and prevent the gas from passing behind and around the piston ring. *This point is as important as the fit of the piston ring against the cylinder wall.*

Fig. 10 shows the square edges of the piston ring slots. Fig. 11 shows the square edges of piston ring slots worn to a bevel by piston rings that had too much vertical play.

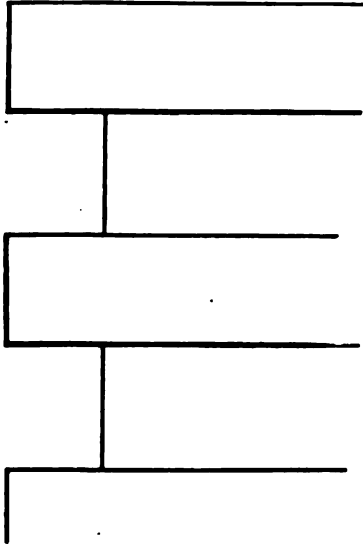

Fig. 10, showing square edges of piston ring slots. Operator must never allow the square edges to become beveled by loosely fitting piston rings

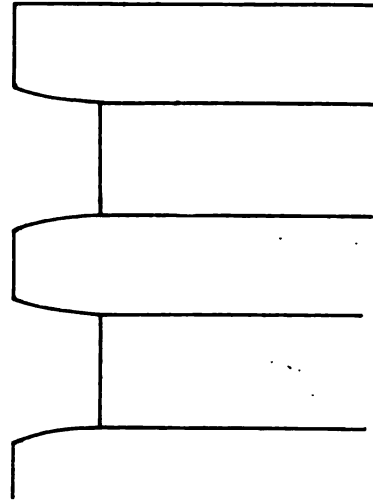

Fig. 11, showing square edges of piston ring slots worn to a bevel by piston rings that had too much vertical play.

- 117** — Fig. 11 shows the square edges of the piston ring slots worn to a bevel by poorly fitting piston rings. If these square edges are worn to a bevel, it will be impossible to prevent the passage of gases above and below the piston ring and the edges of the slot because the lubricating oil cannot form an effective seal when there is much vertical movement of the piston ring in the slot. *The dry air cleaning device that is used in conjunction with the carburetor should be kept in operation at all times, as it excludes from the engine the dirt that normally would gain access to the combustion chamber and produce wear on the piston ring slots, in addition to the wear that would occur from a loosely fitted piston ring.*

## Removing the Piston

- 118** — When it is desired to remove the piston for the purpose of cleaning under the piston rings, the operation can be done at a minimum of time and trouble. In all engines with standard pistons the pistons can be removed through the crankcase door. In engines that go into high altitudes and are equipped with high compression pistons, it is necessary to remove the piston through the top of the cylinder, due to its increased length. Clean crankcase doors carefully before entering crankcase. *Remove the spark plugs so that compression or vacuum will be released and not interfere with handling the piston.* By means of the flywheel revolve the crankshaft until the lower connecting rod bearing of the piston desired is accessible. Remove the lower half of the connecting rod bearing. Rotate the flywheel (with the upper half of the connecting rod bearing still on the crank throw) until the bearing is almost on the opposite side of

---

## CARE AND OPERATION

---

the crankcase. This position is shown in position 1. Carefully note the angle that the web of the crankshaft makes with a horizontal line through



**Position 1**



**Position 2**



**Position 3**



**Position 4**

**Fig. 12—Showing Removal of Piston**

the crankcase. At this point, with a light bar unseat the upper half of the connecting rod bearing from the crank throw and lower it until the upper part of the bearing spans the oil tunnel in the base of the crank-

shaft. *In removing the connecting rod from the crank pin bearing, care must be exercised not to drop the connecting rod and piston or damage the babbitt bearing.* Position No. 2 indicates the second step in the removal of the piston. When the connecting rod bearing spans the oil tunnel in the crankcase, the piston can be pulled forward, as in position No. 3, and its removal is easily effected. *At this point, however, it may be necessary to rock the crankshaft one way or the other to obtain the necessary angle on the crankshaft to allow the piston to come out of the door.* Position No. 4 illustrates the method of final removal of the piston from the crankcase.

### Inserting the Piston

- 119** — Inserting the piston after cleaning or repairing is accomplished in the reverse direction, except that a light bar must be used under the piston to force it into the cylinder. The bottom edge of the cylinder is cut at an angle so as to aid in compressing the piston rings and making the insertion of the piston an easy matter. After the piston has been inserted in the cylinder and the lower half of the connecting rod bearing assembly placed on the connecting rod, **Be Sure That All Cotter Keys Are Placed on the Connecting Rod Bolts.** Also be sure that the oil dipper is pointing the right way. One side of each connecting rod on both upper and lower half is stamped with a letter so no mistake can be made in assembling. Occasionally, however, an operator may reverse the direction of the oil dipper.

### Fitting Piston Rings

- 120** — Accuracy and care should be used in fitting piston rings in a cylinder. Three factors have to be taken into consideration:
- The fit of the piston ring in the cylinder before placing on the piston.
  - The fit of the piston ring in the piston ring slot on the outside.
  - The fit of the piston ring in the piston ring slot.

The average engineer should be able to get perfect adjustment on new piston rings if the following precautions are observed:

### Fit the Ring in the Cylinder First

- 121** — *Allowance has to be made for the piston ring's expansion lengthwise, so that when the piston and cylinder are up to operating temperature the free ends of the piston ring will not meet and cause bind of the piston ring against the cylinder wall.* Broken laps and broken piston rings mean that sufficient provision for expansion was not made.
- 122** — Remove with a file any “wire” or rough edges on the corner of the piston ring that comes in contact with the cylinder wall, then insert

---

## CARE AND OPERATION

---

the piston ring in the cylinder so that it seats square. If the ring is inserted in a cylinder that is mounted on an engine a small round mirror is a very efficient aid in examining the separation of the split.

- 123** — When material has to be removed from the end of the piston ring split to provide the necessary opening for expansion, clamp a fine mill file in a vise, open the piston ring and clamp the ends of the piston ring squarely over it and remove material. Be careful never to damage the piston ring split surfaces where they come together horizontally.
- 124** — For the second and third rings the split in the piston ring should separate .012 (twelve thousandths) of an inch. A standard metal shim in the connecting rod lower bearing of a "Caterpillar" engine is .012 inch thick and makes a very convenient guide to gauge the separation. **FOR THE TOP PISTON RING, HOWEVER, THIS SEPARATION IS NOT SUFFICIENT**, due to this piston ring's proximity to the piston head, where the heat is severest, and *a distance nearly twice the separation given the second and third rings must be given*. The top piston ring split should separate .020 (twenty thousandths) of an inch. This distance usually has to be estimated, using two shims, unless the operator possesses a "feeler", giving the exact measurement.

### Clean the Piston Ring Slot

- 125** — *The piston ring slot should be scraped absolutely clean of all carbon deposit and washed off with kerosene.* It is useless to fit a piston ring unless this condition exists, because the deposit will produce a bind, interfering with accurate fitting, and in addition will lift the piston ring off contact with the edges of the piston slot and afford an opportunity for a carbon deposit to build up immediately.
- 126** — Scrape the piston ring slot clean with a flat metal scraper. **NEVER USE A FILE ON THE PISTON RING SLOT.** *If it is not possible to remove all the carbon, 000 sandpaper under a flat stick should be used, bearing lightly and bringing the piston ring slot to a bright surface.* **NEVER USE EMERY CLOTH FOR THIS OPERATION.** Rinse the slots, when finished, with kerosene, and wipe clean with a soft cloth.

### Fit the Piston Ring in the Piston Ring Slot

- 127** — After the piston ring has been fitted in the cylinder, it should be fitted to the piston ring slot by revolving the piston ring **ON THE OUTSIDE OF THE PISTON AND INSIDE THE SLOT.**
- 128** — If the piston ring does not have free movement in the slot, *some material will have to be removed from the ring.* Obtain a flat board over which spread a quantity of fine carborundum powder and cup grease mixed into a thick paste, or use Clover Leaf Valve Grinding Compound or its equivalent; lay the piston ring flat in this mixture and rotate till a suffi-

cient quantity of metal has been removed to allow freedom of movement in the slot. *Wash the ring with kerosene, not distillate, and wipe clean before trying the ring in the slot.*

### Putting the Ring in the Slot for Fitting

- 129** — One of the most convenient tools to have is a piston ring remover, as by its use the piston ring will not be sprung out of round by careless handling or forcing. If removers are not available, three metal guides, one-fourth inch wide, one-sixty-fourth of an inch thick and about six inches long, should be provided. In taking off or placing piston rings on the piston, these guides should be placed equally around the piston and underneath the piston ring.

### Final Fit of Ring in the Slot

- 130** — When the piston ring is placed in the slot on the piston, it should be free to move in every direction horizontally, *but should move only a slight amount in the vertical.* This vertical movement must be limited from .001 to .0015 (one to one and one-half thousandths) of an inch, so that the expansion will almost close the piston ring slot on the top and the bottom, a thin film of lubricating oil being the final seal to retain compression and prevent the passage of the products of combustion around the ring in the slot. A smooth brown cigarette paper usually micrometers .001 to .00125 of an inch and makes a convenient guide to gauge the vertical movement. If the piston rings are fitted too loose in the beginning, wear on the square bevel edges will ultimately produce the condition shown in Fig. 11 page 31.
- 131** — If the operator is careful in taking care of the engine when new and painstaking when fitting new piston rings, the square edges of the piston ring slot should be maintained indefinitely, provided the dry air cleaning device is used continually.

### Lubricate Rings Before Installing Piston in Cylinder

- 132** — Before placing the piston with its correctly fitting rings in the cylinder, a light film of oil should be given the rings and the piston. However, do not flood the piston ring slots with oil, as the only lubrication they need is on the outside. Space the splits in the piston ring round the piston so that no two of them will be in line.

### Importance of Piston Ring Fit

- 133** — Upon the perfect fit of the piston rings and valves depends the successful operation of the engine. A PERFECT CARBURETER ADJUSTMENT CANNOT BE OBTAINED IF EITHER OF THESE PARTS IS NOT



---

## CARE AND OPERATION

---

**GAS TIGHT.** If the piston ring leaks either at the contact with the cylinder or around the piston ring due to the slot being beveled, or the piston ring being too narrow, the intake stroke will be interfered with and compression of the fuel will not reach the desired point. In case of a ring having good fit against the cylinder wall and a poor fit in the piston ring slot, the products of combustion will be forced downward past the top of the piston ring, around back of the ring and out at the bottom and carbon will be deposited on the low places and built up, possibly ultimately resulting in scoring the cylinder. If the piston ring has a good fit in the piston ring slot and a poor fit against the cylinder wall, the gases will have direct access to the crankcase.

### Use Care in Handling Piston Rings

- 134** — Piston rings should be handled carefully and when opened to put on piston should not be sprung sideways. A ring can easily be sprung so that it will produce a rocking motion when laid flat on a flat board or iron bench plate and tapped with the fingers in different parts. It is impossible to fit a rocking or cocked piston ring. Piston rings should not be carried indiscriminately with other tools in the tool box. Make provision to carry piston rings separately and stacked one on top of the other.

### Valves

- 135** — All valves used in the "Caterpillar" engine are made of mild steel stems with cast iron heads. The stem is first threaded into the valve head and then electrically welded into place, producing a perfect union between the two metals. The upper end of the valve stem is case hardened. Two case-hardened lock nuts are provided for adjustment. The intake valve lifts 15-32 inch. The exhaust valve lifts 9/16 inch.
- 136** — Fig. 13 shows a 45 cylinder head with one valve stem guide and valve assembly removed.



**Fig. 13**

Reading from left to right, the cut shows two case-hardened lock nuts, valve spring, valve stem guide, valve and cylinder head with one valve removed.

## Valve Stem Guides

- 137** — The valve stem guide, which is the part subjected to wear, can be readily removed by driving it out of the cylinder head and a new one can then be inserted. Fig. 14 shows a cross-section view of the cylinder head and the valve stem guide with the valve in place.

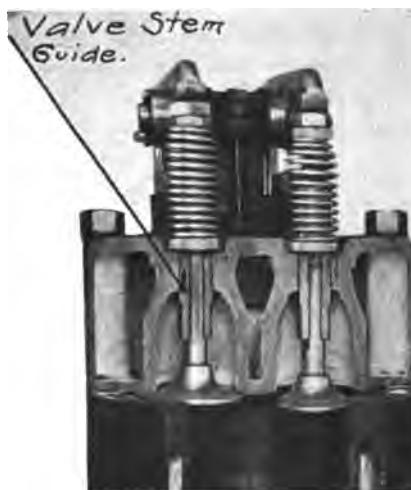

Fig. 14

## Valve Stem Guide Lubrication

- 138** — The valve stem guides should be lubricated four times a day with a mixture one-half cylinder oil and one-half kerosene. This penetrates better than straight cylinder oil. The lubrication of valve stems and guides should never be neglected.

## Valve Grinding

- 139** — To grind the valves of the 45 engine, remove the cylinder head, remove the lock nuts and valve springs, *being careful to note that the weaker valve spring is on the intake valve and must be replaced in its proper position.* Place the cylinder head in a vise so that a good leverage can be obtained in grinding. A bit can be made to fit the slot in the valve head and work in the socket of the brace which will make an effective valve grinding tool.

When the valve is disassembled, examine the fit of the valve stem in the valve stem guide, particularly on the intake valves, and if worn replace the valve stem guide with a new one.

- 140** — Use carborundum powder mixed into a paste with cup grease, or use Clover Leaf Valve Grinding Compound or an equivalent material. *In grinding valves, never use emery.* In grinding valves do not use a circular motion. Grind valves with a back and forth motion, turning about one-quarter the way around. After several turns, lift the valve off its seat and bring it about one-quarter of a turn towards the right. Seat valve and grind as before. Continue this stepping the valve around so that all the high spots will come in contact with each other, until the valve is ground to an even seat. To watch the progress of the work, wash the valve and valve seat with kerosene.
- 141** — *When the grinding is finished, flush the valve stem, valve stem guide, valve seat and cylinder head thoroughly with kerosene to remove all traces of the grinding compound. Never allow any grinding compound to get into the cylinder.*
- 142** — It is recommended that after valves are ground in, the valve stems be given one-quarter of a turn daily. This can readily be accomplished by

---

## CARE AND OPERATION

---

putting a wrench onto two lock nuts and keeping track of the direction of turn. This will keep the valve seat worn evenly and make less valve grinding necessary. This should not be attempted until just after the valves have been ground.

### Governor

- 143** — The function of the governor is to decrease the opening of the butterfly or throttle when the engine reaches a certain speed in order to hold engine speed constant under load conditions. The only function of the throttle lever on the quadrant on the steering wheel is to close the butterfly or throttle.

### Governor Adjustment

- 144** — Fig. 15 shows a sectional view of the governor, together with the attached levers, springs, brackets and quadrant. To adjust the governor proceed as follows:

*First: With engine at rest,* release the two set collars M1045 (A) and M1045 (B) at the left of slide Z273, then place hand lever E2768 in position at end of quadrant closest the engine, thus placing the butterfly or throttle in full open position. The set collar M1045 (C) to the right of Z273 in the figure and ahead of the spring M1046 should be adjusted to allow the butterfly shaft to assume full open position. The action of the spring M1046 is to exert pressure tending to open the butterfly or throttle.

(NOTE.) Putting the throttle E2768 forward does not actually operate the butterfly shaft as the action of the levers M9538, M9539 and M9540 is only positive or "stiff" to the loop at the end of M9540. At this point the spring M1046 automatically opens the throttle if the governor is in adjustment.

An operator should never make the mistake of thinking that he can govern the engine better than the governor, by rigging the levers so that the action of the hand lever E2768 will be positive on the butterfly shaft, thus cutting the governor out of action. This is termed in the field "driving on a stiff throttle." A tractor engineer occupied with steering the tractor and watching the apparatus being hauled has no time to anticipate the fuel requirements of the engine, and no matter how intelligent he is he cannot perform the functions of a correctly adjusted governor.

*Second:* The tension on the plunger spring M1041 should be regulated with the set screw M2047 so that when the governor ball C109 is grasped with the hand and pulled outwards the end of the lever on the governor ball will force the governor plunger M1037 at a seat against the governor bracket C110.

*Third:* A bronze washer is placed between the stationary swivel collar M1040 and the rotating governor plunger M1037 to take the wear. If slack occurs at the swivel when the lever M1169 is moved, a new washer will have to be inserted before the governor adjustment can be properly made. These bronze washers can be obtained from the factory in various thicknesses to suit the requirement. A washer is also placed between the head of the set screw M2047 and the swivel M1040.

*Fourth:* Adjust the tension on spring M1043 so that the action to keep the slack in the lever M1169 is positive.

**“CATERPILLAR” 45 TRACTOR**

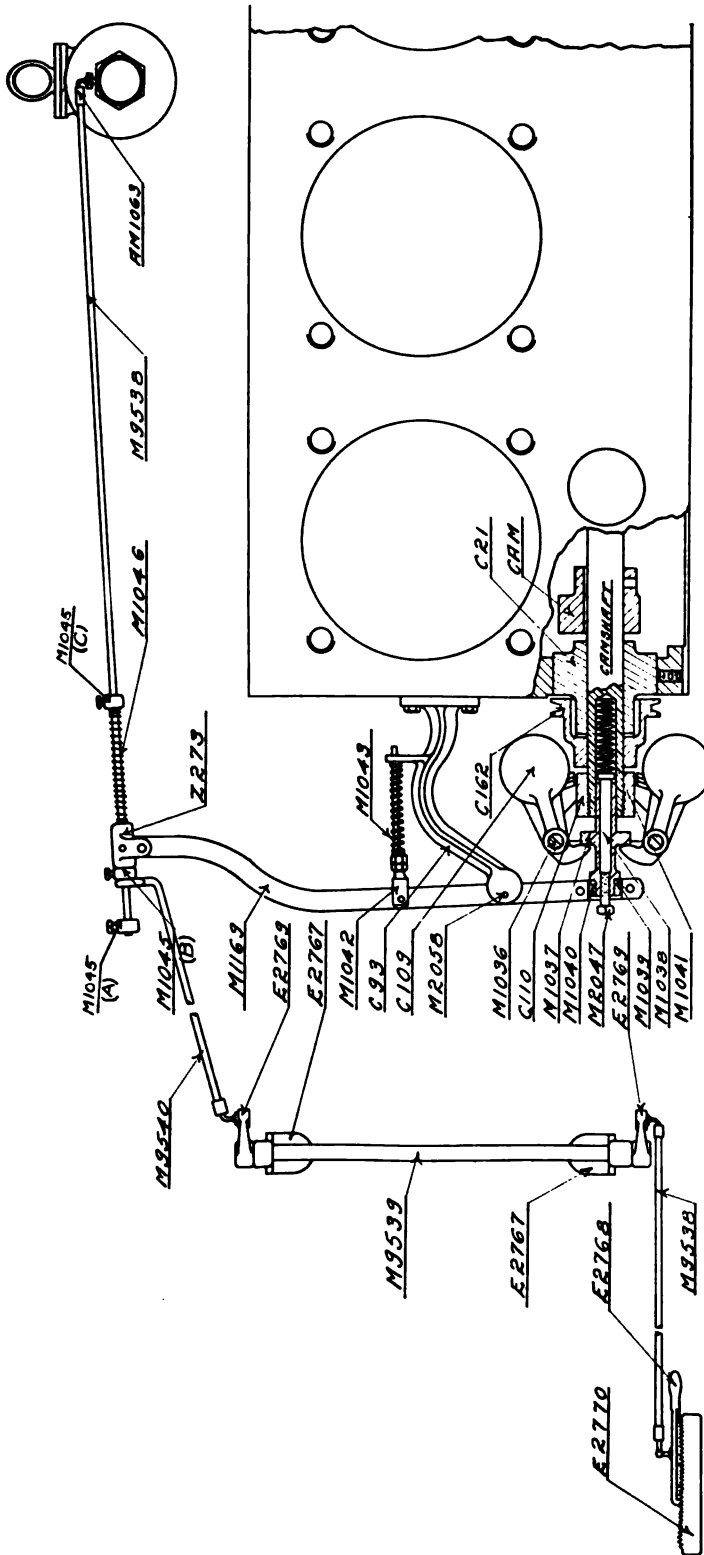

**Fig. 15. Governor.**

- |  |                                 |
|--|---------------------------------|
| E. 2770—Motor control quadrant               | M1038—Plunger pin               |
| M9539—Carburetor control shaft.              | M1041—Spring                    |
| E. 2767—Bracket for Car. con. shaft          | Z. 273—Slide                    |
| E. 2768—Hand lever                           | M1043—Spring                    |
| M9538—Carburetor control rod.                | C. 162—Grooved pulley for oiler |
| M1045—Collar                                 | M1046—Spring                    |
| M1169—Governor lever                         | M9540—Carburetor control rod    |
| E. 2769—Throttle control arm                 | C. 21—Cam shaft bushing ends    |
| E. 2767—Bracket for Carburetor control shaft | M9538—Carburetor control rod    |
| M1042—Tension rod                            | A. M1063—Ball and socket joint  |

---

## CARE AND OPERATION

---

*Fifth:* With the adjustment on the hand throttle, levers and butterfly shaft made and with the governor itself in proper adjustment, *replace the set collar M1045 (B) to the left of Z273, so that when the governor ball C109 is moved slightly by hand the slide Z273 engages the set collar M1045 and commences to close the butterfly or throttle through the lever M9538; then place set collar M1045 (A) so that when the hand lever E2768 is brought back to full retard the loop on the end of M9540 will engage M1045 (A) and close the butterfly or throttle. The distance that M1045 (A) and M1045 (B) are separated is about 1 $\frac{5}{8}$  inches.*

### Governor Plunger and Spring

- 145** — The set screw M2047 should not be so far advanced on the governor plunger spring as to limit the action of the governor. This is a mistake that operators frequently make. Tension on the spring should be such that when the governor is at rest, moving the governor ball C109 throughout its range will seat the governor plunger and spring should be disassembled occasionally, cleaned and oiled.

To increase speed of the engine, screw M2047 "in." To decrease speed, screw M2047 "out."

### Bronze Governor Washer

- 146** — *Probably the most neglected part of the governor is the bronze washer M1039. This bronze washer is placed between the governor plunger M1037 and the swivel M1040 and is not given much attention by the average operator as the part is out of sight. This washer takes the wear between the swivel M1040, which is stationary, and the governor plunger M1037, which is continually revolving. This washer should be replaced when worn. Keep all play on swivel adjusted by placing bronze washers on both sides. These washers can be obtained in sets with varying thickness to secure proper adjustment.*

### Lubrication of Governor

- 147** — The governor should be lubricated with Cylinder Oil. Lubricate the swivel and bronze washer, M1039, and governor ball pin M1036 four times a day. Lubricate all other moving parts on governor lever twice a day.

### Carbureter

- 148** — A complete discussion of the carbureter is contained in Service Bulletin No. 6, to which the reader is referred, as all subjects relative to carbureter adjustment are discussed therein in detail. Fig. 16 shows a sectional view of the carbureter.

## Adjustment of Carbureter

**149** — Specific directions can not be given for adjusting the carbureter. The adjustment of the carbureter depends upon the conditions under which the engine is operated, atmospheric conditions, elevation, quality of fuel used and load pulled. *The best adjustment is to give the engine as much air and as little fuel as the engine will handle to have the required power, without over-heating.*

**150** — The function of the carbureter is to change the liquid fuel into a vapor mixed with such proportions of air that an *explosive or instantaneous burning mixture* is obtained. *If there is more air or less air supplied than is required to make a perfect mixture, the fuel vapor mass will be a slow burning mixture, which will cause rapid overheating of the engine, carbon deposit and lack of power.*

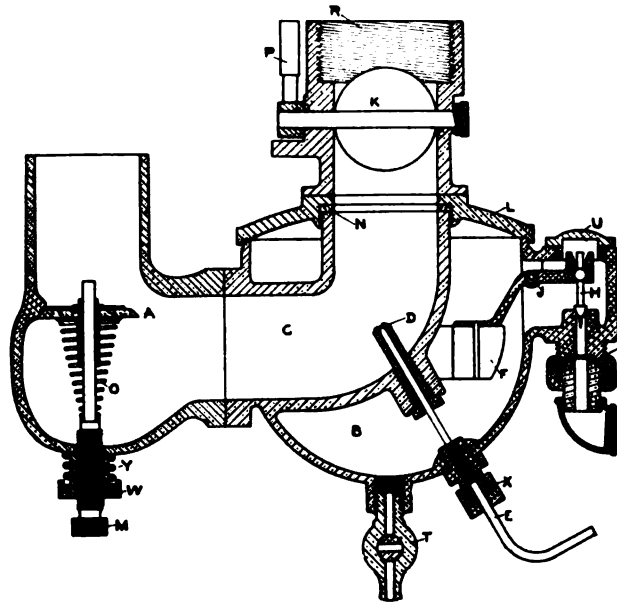

**Fig. 16.—Carbureter.**

**Showing Needle-Valve and Air Adjustment.**

- |                           |  |
|---------------------------|--|
| A—Leather Air Valve Disc. | M—Air-Valve Adjustment Screw.              |
| B—Float Chamber.          | N—Cork Gasket.                             |
| C—Mixing Chamber.         | O—Air-Valve Spring.                        |
| D—Spraying Nozzle.        | P—Throttle Lever.                          |
| E—Needle-Valve.           | R—Pipe Connection.                         |
| F—Float.                  | T—Drain Cock.                              |
| G—Reversible Union.       | U—Float Valve Cap.                         |
| H—Float Valve.            | W—Lock-Nut.                                |
| J—Float Hinge.            | X—Packing-Nut and Needle Valve Connection. |
| K—Throttle Disc.          | Y—Lock Springs.                            |
| L—Float Chamber Cover.    |  |

## All the Air Must Go Through the Carbureter

**151** — ALL THE AIR FOR THE FUEL VAPOR MIXTURE MUST GO THROUGH THE AIR INTAKE OF THE CARBURETER IN ORDER THAT THE LIQUID FUEL MAY BE CHANGED INTO A PERFECT VAPOR. The necessary mechanism in the form of air valve and spring is incorporated in the carbureter to obtain every adjustment.

*When all the air does not pass through the air intake of the carbureter, it is not possible to secure an accurate adjustment.* In addition, the valves

---

## CARE AND OPERATION

---

must open and close on time and the magneto must fire the compressed fuel vapor charge at the correct point.

There are five places where air can enter the cylinder besides through the carbureter properly.

- a. Throttle shaft or bearing being worn.
- b. Intake manifold leaking.
- c. Intake manifold gaskets leaking.
- d. Worn valve stem guides.
- e. Poorly fitting piston rings or worn pistons and cylinders.
- f. Auxiliary air devices.

**152—** An accurate carbureter adjustment cannot be secured until all air is excluded from gaining admission through these points. Air gaining admission through any of these points dilutes the mixture that has passed through the carbureter and can cause rapid over-heating of the engine and lack of power.

a. The throttle (or butterfly shaft, as it is commonly called) or bearing may be worn oval through the action of the governor. This particular bearing is made extra large to resist wear, but in time the bearing may be worn to an oval shape or the butterfly shaft itself may be worn. *This point is probably overlooked more than any other as a cause of difficult carbureter adjustment and overheating of the engine.* The proper diameter for the throttle shaft is nine thirty-seconds of an inch. The length of the shaft varies for the different size carbureters.

There are two ways of remedying this condition. First, obtain an oversize throttle shaft and then ream the bearing with a five-sixteenths reamer and insert the oversize shaft. Second, drill the bearing, fit a bushing, ream and install a standard size throttle shaft.

b. The intake manifold must be kept intact. Under no conditions must it ever be tapped except to receive the Stewart Vacuum System pipe. The intake manifold should not leak air at any point.

c. *The intake manifold gaskets must not leak air and should seat perfectly.* The gaskets contain asbestos fibre and when once compressed and then removed it may be difficult to obtain an air-tight fit. A leaky intake manifold gasket is best replaced by a new one. To detect a leaky intake manifold gasket, with an ordinary oil can pour oil on the intake gasket while the engine is running, and note if it disappears by the oil being drawn into the intake manifold. The remedy is new intake manifold gaskets.

d. Worn valve stem guides on the intake valve can admit to the mixture air that has not passed through the carbureter. The correct adjustment for

this is to insert a new valve stem guide. All the valve stem guides on “Caterpillar” Engines are readily removed by driving them out. The valve stems and valve stem guides should be lubricated four times a day with a mixture one-half kerosene and one-half cylinder oil. A worn valve stem guide can only be detected by disassembling the valve and making an examination of it. When an engine overheats in one cylinder only, the trouble can frequently be traced to a leaking intake manifold gasket or a leaking valve stem guide, provided, of course, that the oil level is at the correct point, and water circulation is good.

e. Poorly fitting piston rings or worn pistons can admit air to the cylinder without the air passing through the carbureter. This point can readily be determined by the lack of compression and the lack of power. The remedy is to fit new piston rings. See Service Bulletin No. 4.

f. Auxiliary air devices should never be used on the “Caterpillar” Engine. *If the carbureter is in correct carbureter adjustment, there is nothing that an auxiliary air device can do to add to the efficiency of the mixture.* It is not possible to get an accurate carbureter adjustment with the use of an auxiliary air device. All the air for the mixture must pass through the carbureter to secure perfect vaporization of the fuel. If maximum fuel economy of the engine is not obtained with the carbureter, it may be that the adjustment is unbalanced somewhere. *The necessary mechanism in the form of an air valve and spring is incorporated in the carbureter to obtain every adjustment as far as air is concerned.* After a while the auxiliary air device will leak air and be a source of constant annoyance, and can be a fertile cause of engine overheating.

## Carbon

- 153** — The first and most important consideration in keeping an engine free from carbon is the complete combustion of the fuel, as from this source the largest proportion of carbon is deposited. For further detail, see Service Bulletin No. 5 on carbon and carbon troubles.

## Valves Must Operate Correctly

- 154**— To secure a perfect carbureter adjustment, the valves must seat perfectly and open and close correctly. Before proceeding with the carbureter adjustment it is absolutely necessary to be sure that when the cam is disengaged on each particular valve rod guide, all the slack is taken up on the valve tappet, valve rod and rocker arm, *so that the rocker arm has a clearance of one thirty-second of an inch over the valve stem. This distance must not be varied.*



## CARE AND OPERATION

Fig. 17 shows a diagram of the cam, valve rod and rocker arm giving a clearance of one thirty-second of an inch over the valve stem when the cam is pointing downwards. Carbureter adjustment can be interfered with very readily and the engine can lose power if the clearance is greater or less than one thirty-second of an inch.

- 155 — The magneto must fire the compressed charge at the proper point. See paragraph 180, page 52, for the proper timing of the magneto.

### When to Commence Carbureter Adjustment

- 156 — In general, it may properly be said that the adjustment of the carbureter commences by being sure the butterfly shaft and bearing, intake manifold, intake manifold gaskets, valves, valve stem guides, piston and piston rings exclude the entrance of air from the combustion chamber, thus causing all the air to enter through the carbureter. Mechanical details to be looked after are to make sure that the rocker arm has a clearance of one thirty-second inch from the valve stem and that the mixture is fired at the correct point by the magneto.

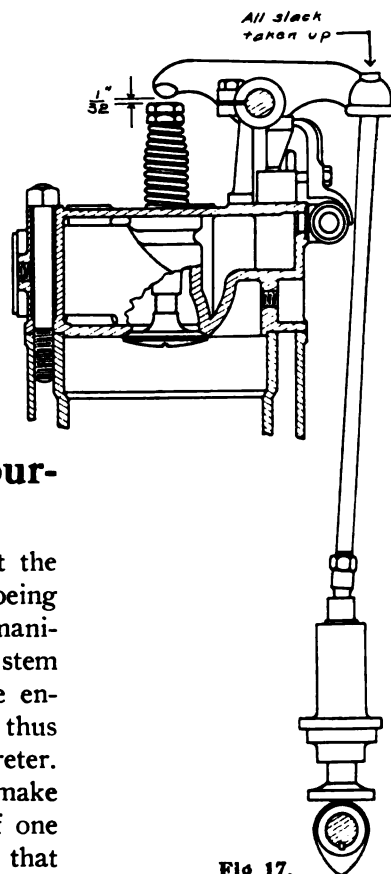

Fig 17.  
Cam, Valve Rod and  
Rocker Arm.

### Adjusting Carbureter

- 157 — After all connections are properly made, see that the air valve "A" seats lightly but firmly. This is regulated by adjusting screw "M." Turning adjusting screw "M" to the right increases, and turning to the left decreases the tension of the air valve spring "O." Care should be taken not to screw needle valve "E" into spray nozzle tightly. It has a tendency to increase the size of the opening and will give a richer mixture. The needle valve "E" should be closed *lightly* and then opened about one complete turn.
- 158 — In making adjustment for full load, open throttle wide, advance spark about one-quarter, and if the engine does not run smoothly, but "backfires," it indicates that the tension of the air valve spring "O" is too weak. If, after about two complete turns of adjusting screw "M" to the right, the irregularity is not eliminated, give the needle valve "E" about one-tenth to one-quarter turn to the left, which gives the mixture just a trifle more fuel.
- 159 — Fig. 18 shows a cut-away section of the carbureter, intake and exhaust manifold on the 45 engine with the various parts indicated.

## Over-Lean Mixture

160 — In an over-lean mixture, the mixture is slow-burning instead of an explosive mixture and actual flame is present during the exhaust stroke. At the time that the intake valve is unseated to admit the fresh fuel charge, flame is still present in the combustion chamber. It travels down the intake manifold and causes what is known as a "pop-back" in the carburetor. This condition heats the engine very rapidly.

### CAUTION:

Never use a priming can filled with gasoline on the air intake of a carburetor when the engine is running. A "pop-back" may occur that will cause the priming can to explode. If necessary, prime the carburetor with gasoline before starting. Priming the cylinders with the least quantity of gasoline possible is all that is usually required.

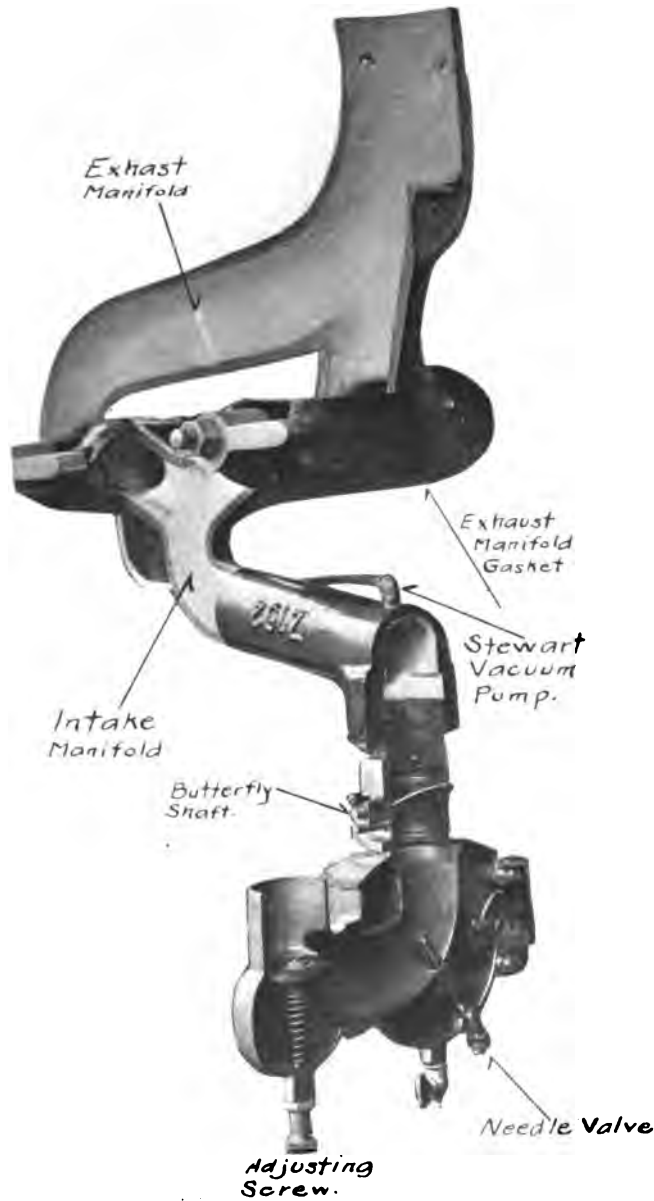

Fig. 18.

## Over-Rich Mixture

- 161** — An over-rich mixture is a slow-burning mixture instead of an explosive mixture. Black smoke is present in the exhaust gases. This black color is free carbon, part of which remains in the combustion chamber and is baked on the walls, valves and piston head. With an over-rich mixture the circulating system is overtaxed to carry away the surplus heat and an undue strain is placed on the lubricating oil.

**CAUTION:** Care should be taken not to screw needle valve "E" into the spray nozzle tightly as it tends to increase the size of the opening and give a rich mixture. This point is one that the average engineer does not detect very readily. At the end of a run it is always advisable to stop the engine by letting it die for want of fuel. The best way to shut off the fuel is to close the shut-off cock on the pipe line rather than to use the needle valve.

It is possible to obtain a rich mixture by having the tension on the air valve spring "O" too tight or the needle valve "E" open farther than required. The normal opening of the needle valve is from three-quarters to one and one-quarter turn. Under extreme conditions the needle valve may have to be operated from one and one-quarter to one and three-quarter turns. If this amount is necessitated, the engine should be carefully examined to see what is causing the increased fuel requirement. *Over-rich mixture in the carbureter is responsible for over 60 per cent of the total actual carbon content in the engine.*

## Float Setting

- 162** — The top of the cork float "F" should be level when at rest and one thirty-second of an inch above the top of the spray nozzle in the 1/2-inch, 1 1/4-inch and 1 1/2-inch carbureters, and one-sixteenth in the 2-inch carbureter.

## Float Valve

- 163** — After constant use the float valve "H" becomes worn, which changes the level of the float and makes it difficult to get a good adjustment on the carbureter. In this case, a new valve should be obtained. Don't attempt to grind this valve to its seat.

The correct adjustment on the float valve is to have the float valve adjusted so you can feel just a little play between the ball on the float valve and the float valve retainer nut.

## Disassembling the Carbureter

- 164** — Care should be used when taking the carbureter to pieces to see that the cork gasket "N" in the bowl is not broken. If broken it should be replaced by a new one.

## Stopping the Engine

- 165** — It is advised when stopping the engine at the end of a shift or when the engine is to be stopped for a considerable time, that the fuel supply be closed off from the carbureter by the shut-off cock in the pipe line and the engine allowed to die for want of fuel.
- 166** — If the engine is stopped by short-circuiting the magneto, there will be some wet distillate vapors in two of the cylinders, one being on the compression stroke and the other being on the admission stroke. These vapors condense, fall on the piston head and may gain admission under the piston rings, diluting the oil supply under the piston rings, gaining admission past the pistons and into the crankcase oil supply. Shutting off the fuel lets the engine die with dry cylinders, which facilitates starting.
- 167** — A dry air cleaning device that depends upon centrifugal force of the air to throw dirt to the outside of the container is employed and its continuous use is recommended. The dry air cleaner removes from the carbureter air supply the dust and dirt that would normally go through an engine without its use. Do not remove the glass jar container while the engine is in motion.

## Vacuum System

- 168** — The Stewart Vacuum System employs a small tank installed on cylinder No. 4. This tank is connected by brass tubing to the intake manifold, also to the fuel supply tank and to carbureter. The partial vacuum that occurs in the intake manifold is transmitted to the vacuum tank and this vacuum is utilized then in lifting the fuel from the fuel supply tank into the upper chamber of the vacuum tank. Fig. 19 shows a sectional view of the Stewart Vacuum Tank. Fig. 20 shows an assembly of the float and lever action.
- 169** — The Stewart Vacuum Tank consists of two chambers, the upper one is the filling chamber and the lower one is the emptying chamber. Between these two chambers is a partition in which is placed a valve. The partial vacuum in the intake manifold on the intake stroke creates a vacuum in the upper chamber and this vacuum closes the valve between the two chambers and also sucks or pumps fuel from the main supply tank into this chamber. As the fuel goes into this upper chamber, it raises a float valve. When this float valve has risen to a certain point it opens a valve which shuts off the suction and at the same time opens an air valve. This admission of outside air releases the vacuum suction, thus causing the valve leading into the lower chamber to open and through this the fuel immediately commences to flow into the lower or the emptying chamber. This lower chamber is always open to the outside air so that nothing ever can prevent the fuel in this lower chamber from feeding through its connection to the carbureter in a perfect, even, uninterrupted flow.

*A* is the suction valve for opening and closing the connection to manifold and through which a vacuum is extended from the engine manifold to fuel tank.

---

**CARE AND OPERATION**

---

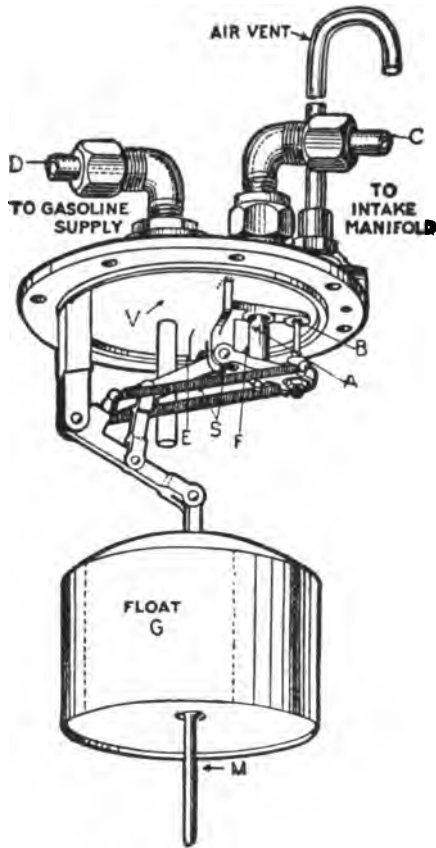

**Fig. 19.**

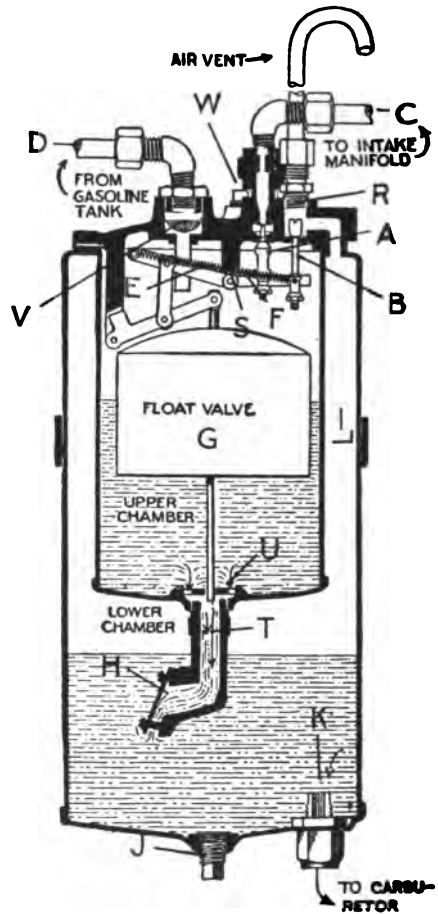

**Fig. 20.**

*B* is the atmospheric valve, and permits or prevents an atmospheric condition in the upper chamber. When the suction valve *A* is open and the suction is drawing fuel from main reservoir, this atmospheric valve *B* is closed. When the suction valve *A* is closed, then the atmospheric valve *B* must be open, as an atmospheric condition is necessary in the upper tank in order to allow the fuel to flow through the flapper valve *H* into the lower chamber.

*C* is pipe connecting tank to manifold of engine.

*D* is pipe connecting vacuum tank to main fuel supply tank.

*E* is lever to which the two coil springs *S* are attached. This lever is operated by the movement of the float *G*.

*F* is short lever, which is operated by the lever *E* and which in turn operates the valves *A* and *B*.

*G* is the float.

*H* is flapper valve in the outlet *T* (see illustration). This flapper valve is held closed by the action of the suction whenever the valve *A* is open, but

it opens when the float valve has closed the vacuum valve *A* and opened the atmospheric valve *B*.

*J* is plug in bottom of tank which can be removed for draining or cleaning tank. This plug can be replaced with a pet cock, to be used for drawing off fuel for priming or cleaning purposes.

*K* is line to carbureter extended on inside of tank to form pocket for trapping water and sediment.

*L* is channel space between inner and outer shells, and connects with air vent *R*, thus admitting an atmospheric condition in lower chamber at all times, and thereby permitting an even uninterrupted flow of fuel to carbureter.

*M* is the guide for float.

*R* is an air vent over the atmospheric valve. The effect of this is the same as if the whole tank were elevated and is for the purpose of preventing an overflow of fuel should the position of the tractor ever be such as would raise the fuel supply tank higher than the vacuum tank. Through this tube also the lower, or reservoir chamber is continually open to atmospheric pressure, so that the flow of fuel from this lower chamber is always an even, uninterrupted flow.

*T* is the outlet located at the bottom of the float reservoir, in which is the flapper valve *H*.

## Troubles

- 170** — There are very few parts that require adjustment. The most common complaint is that the screen *V* is clogged with sediment from the fuel supply. Remove the screen and clean.

When new, the valve *H* may seat so tightly on its seat that the fuel cannot go from the upper chamber to the lower chamber. After this valve has been freed, further trouble will not be experienced.

The plug *J* is used for the purpose of draining the vacuum tank of water and should be opened occasionally.

## To Remove Top of Tank

- 171** — In removing top of tank after taking out screws, run the blade of a knife around top between cover and body of tank so as to separate gasket without damaging it. Gasket is shellaced to make an air tight joint.

## Connections and Tubing

- 172** — Look over the connections to see that they are absolutely tight. Coupling and elbow connections must always be kept screwed down tight. Care should be taken that tubing contains no sharp flat bends that might retard fuel flow.

## Repair of Tank

- 173 — If you find it necessary to remove the tank for repair, then ship the COMPLETE TANK to the closest Stewart Products Service Station. One is located at 115 East Tenth St., Los Angeles; one at 215 B St., San Diego, and one at 1447 Van Ness Ave., San Francisco. The instruction book and price list of parts of every Stewart System is furnished with the Service Bulletins at the time of delivery of tractor.

## Magnetos

- 174 — Two different types of K-W High Tension Magnetos have been used on the "Caterpillar" 45, the model TK and model HK. The model TK is described briefly in the following, but a complete discussion and price list is contained in Service Bulletin E.

### HK K-W High Tension Magneto

- 175 — Service Bulletin C Revised contains a complete discussion of the Model HK K-W High Tension Magneto. Service Bulletin E contains a complete discussion of the Model TK K-W High Tension Magneto, and but a brief discussion will be given here.

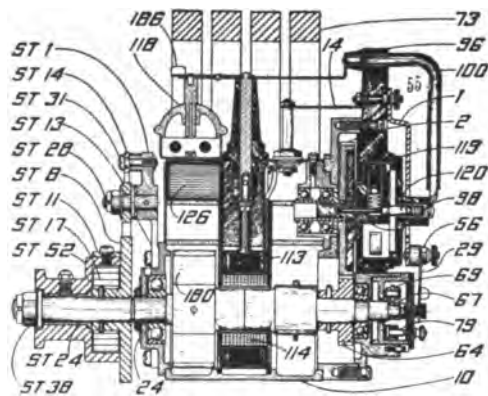

Fig. 21. Model HK K-W Magneto

Fig. 21 shows a longitudinal sectional elevation of Model HK. Study it instead of taking your magneto to pieces. The HK K-W Magneto is so designed that by the removal of one spring, shown at Part 29 in Fig. 21, the circuit breaker can be removed from the magneto. Remove cover nut No. 79. This allows removal of circuit breaker cap and gives access to breaker parts. To gain access to distributor, remove high tension spring No. 100, loosen nut No. 55, removing spider No. 1. *Beyond this point no one but a magneto expert should venture.* The inside of the magneto is not complicated. NINETY-FIVE PER CENT OF ALL TROUBLE WITH THE K-W CAN BE REMEDIED AT THE CIRCUIT BREAKER OR DISTRIBUTOR. Fig. 22 shows a view of the circuit breaker. The breaker bar No. 190 is the moving element in the circuit breaker, being actuated by the cam No. 67 and the roller No. 68. This breaker bar is

tributor, remove high tension spring No. 100, loosen nut No. 55, removing spider No. 1. *Beyond this point no one but a magneto expert should venture.* The inside of the magneto is not complicated. NINETY-FIVE PER CENT OF ALL TROUBLE WITH THE K-W CAN BE REMEDIED AT THE CIRCUIT BREAKER OR DISTRIBUTOR. Fig. 22 shows a view of the circuit breaker. The breaker bar No. 190 is the moving element in the circuit breaker, being actuated by the cam No. 67 and the roller No. 68. This breaker bar is

“grounded” to the magneto. Part No. 191, lower contact bar, and adjusting screw No. 194 comprises the second part of the circuit breaker. *The lower contact bar and adjusting screw No. 191 carries the primary current and is insulated from the rest of the magneto by fibre washers, bushings and plate and it is necessary that the insulation never be destroyed, nor must it be short-circuited with oil, either inside or outside of the circuit breaker.*

## Adjusting Circuit Breaker Points

- 176 — When the points between breaker bar No. 190 and adjusting screw No. 194 fail to separate, one of two things has happened. Adjusting screw No. 194 has been inserted too far and holds breaker arm No. 190 off the cam No. 68, or else the screw located near No. 110 has been made to fit too tight with a screw driver. The breaker points should always meet square. The correct separation of the breaker points is one sixty-fourth of an inch. *A gauge is provided with every magneto and the separation of the points must always be tested and not guessed at.* Be sure that the spring tension on the breaker arm is good and that the points come together in a snappy manner.

*Be sure lock nut on part No. 190 (platinum point screw) is set tight and is free from metallic contact with breaker box or breaker box housing. This is important.*

## Lubrication of Circuit Breaker and Bearings

- 177 — The lubrication of the circuit breaker is essential, *but over-lubrication must be avoided. All parts of the magneto must be lubricated with a light oil like 3-in-1 or Household Lubricant. The use of an oil can to lubricate the circuit breaker or any part of the magneto should absolutely be prohibited.* Use a toothpick or a piece of wire with a notch filed in it near the end resembling a crochet hook. The lubrication of the HK Magneto and particularly the circuit breaker must be limited to one drop at one place. *Lubricate the cam roller wicking No. 68 once every ten days with one drop of oil. Lubricate the screw near 110 with one drop of oil every ten days. Wipe excess oil away immediately. KEEP THE CIRCUIT BREAKER SCRUPULOUSLY CLEAN OF EXCESS OIL and keep the points adjusted to break 1/64 of an inch and most magneto troubles will be eliminated. Never use cylinder oil to lubricate any part of the magneto.*

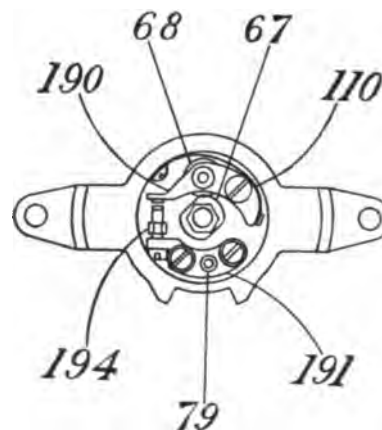

Fig. 22

Apply one drop of oil to each bearing once every fifteen days.



## Circuit Breaker Troubles

- 178 — The insulating washers on lower contact bar No. 191 may be broken by forcing the screws in too far. *If broken, new ones must be put in before magneto will operate successfully, if at all.*

*Excess oil will ground the primary current on No. 191, also causes platinum points to burn up rapidly. Use light oil and wipe excess away immediately.*

*Nut No. 79 must always be firmly seated. This usually can be tightened sufficiently with the fingers. The circuit breaker cover No. 95 is an insulating material and oil and dirt on the outside of the circuit breaker can short-circuit it. Keep the outside of the circuit breaker clean and free from oil. Circuit breaker cover No. 95 must never be broken or checked.*

Spring No. 189 must always make good contact.

*Separate platinum points for breaker bar and adjusting screw are not sold, as they are difficult to install correctly. Complete breaker bars or adjusting screws are sold at a price as low as the cost of putting in and correctly mounting a new point.*

## The Distributor

- 179 — The upper half of Fig. 23 shows a view of the distributor. Unscrew nut No. 55, remove high tension bridge No. 100, remove cap, which gives view of distributor and brush "B." The carbon brush may be removed and scraped if it has a hard, irregular glaze on the surface that distributes the current to the contacts. Occasionally a brush may be worn and carbon dust will be worn off and in falling to the bottom will short-circuit cylinders Nos. 1 and 4. The distributor should be wiped with a clean cloth saturated with gasoline when required. After the magneto has been in service a long time, the face of the distributor may become rough. Dressing the surface lightly with 000 sandpaper is all that will be required.

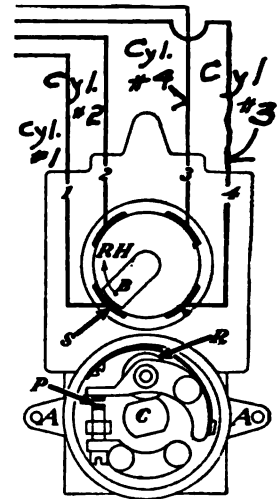

Fig. 23

## To Time Magneto to Engine

- 180 — Refer to Fig. 23 on this page and Fig. 33, page 67.

First: Have cylinder No. 1 on top center as shown in the left side of Fig. 33, page 67, on compression stroke. Have Oldham coupling uncoupled.

Second: Place circuit breaker in full retard position. Rotate the magneto by free end of Oldham coupling until Brush "B" touches segment "S," thus connecting with cylinder No. 1.

Third: Shift the magneto slowly by hand in the proper direction of rotation till the contact points ‘‘P’’ in Fig. 23 are just commencing to separate. This is the firing point of the magneto and in timing the magneto must occur when the piston is on top center with magneto in full retard. From the full retard the circuit breaker can be advanced about 30 degrees.

Fourth: When No. 1 cylinder is right, connect up Oldham coupling with the bolts provided. Proceed to connect up other cylinders as follows: All ‘‘Caterpillar’’ engines fire 1, 2, 4, 3. Cylinder No. 1 is the cylinder nearest the large fly wheel. The secondary connections from the distributors are numbered 1, 2, 3, 4, and do not refer to the engine cylinders. When cylinder No. 1 is on contact and ready to fire, connect terminal No. 2 to cylinder No. 2, then connect distributor block terminal No. 3 to cylinder No. 4 and distributor block No. 4 to cylinder No. 3.

Fifth: Replace all parts of the magneto. Be sure that nut No. 55 is tight, that high tension lead No. 100 is firmly attached, that nut No. 79 is firmly seated. Also see that spring retainer No. 189 has been replaced. There should be a tendency for the engine to kick back slightly when starting, and if it does not, advance the magneto to the point where it does. This is for the purpose of obtaining the spark at the right time, at the instant that the impulse starter is automatically thrown out of action and locked.

## New Type Short Circuiting Switch

- 181 — On the later model HKs the rotary switch has been discontinued and a short-circuiting finger has been substituted that works on the breaker box and against the spider ‘‘I.’’ *To kill the engine with the magneto, all that is necessary is to put the spark lever in full retard position.*

## Starting

- 182 — In starting the engine with this impulse starter, the circuit breaker should be placed nearly in retard position, so that when the engine comes up to normal speed the spark can be advanced by advancing the circuit breaker to the proper point.

If the engine should be started with the circuit breaker in too much of an advanced position, it would still not fire the engine until after it had passed dead center as long as the engine was below speed and the tripping device was operating at every explosion, but as soon as the tripping device would go out of action, so that the spark would occur at the time the circuit breaker was set for, the engine would get its spark too early. Therefore, it is best to operate tripping mechanism with circuit breaker in nearly retarded position and advance spark when the engine comes up to speed as required.

## HK K-W Impulse Starter

183 — Fig. 24 illustrates the impulse starter for model HK K-W Magneto. The impulse - starting device operates only when the trigger ST-14 is set. Normally the shaft is driven straight through the coupling or connection to the engine, and the trigger is automatically thrown out when the engine comes up to speed.

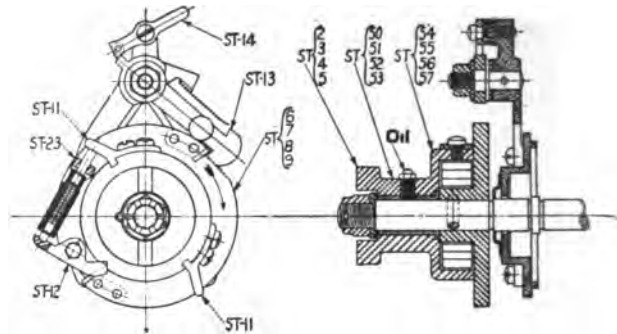

Fig. 24

184 — Full directions are contained in Service Bulletin No. 6 for replacing and putting a new spring in the impulse starter when required; the bulletin also contains a full catalog of repair parts and prices.

## Model TK K-W High Tension Magneto

185 — The model TK differs in many respects from the HK, but the same general principles are employed in the rotor and circuit breaker construction. The impulse starter on the TK differs radically from the type employed on model HK.

Model TK Magnetos must be mounted on a brass or aluminum base or separated by at least one-half inch of non-magnetic material. *If mounted on an iron bracket, brass cap screws must be used, as steel cap screws will demagnetize the magneto by affording a path into the iron bracket.*

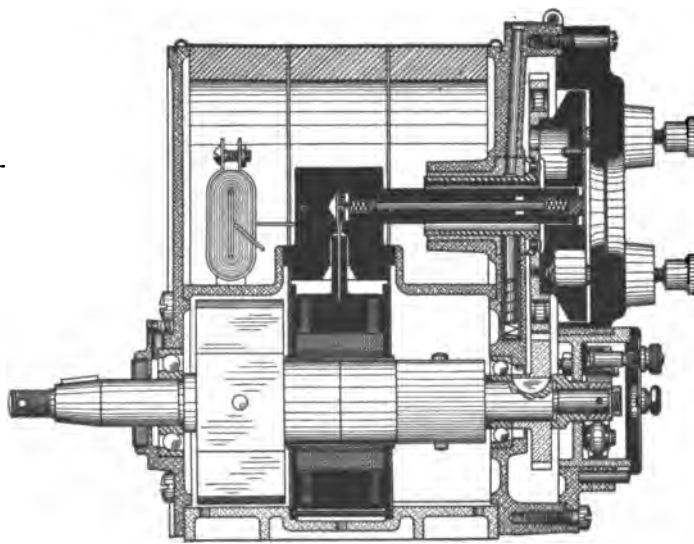

Fig. 25. Cross Section Model TK Magneto

### Length of Cap Screws

*Be sure that cap screws are not too long. They should go into the magneto only three-eighths of an inch; otherwise they will break through the base and strike the rotor. Be sure that lock nuts are placed under the cap screws when installing on the engine.*

186 —

## Cross Section of Model TK

- 187** — Fig. 25 shows a cross section of the model TK with impulse starter removed. All the repairs that can be made to the TK by one not a magneto expert can be made either at the circuit breaker or distributor. The circuit breaker can be removed by shoving the spring clip aside, and by removing the cover nut access can be had to the points. Removing three cap screws will expose the distributor for inspection.

## Circuit Breaker

- 188** — The entire circuit breaker is removable for inspection and adjustment, as in Model HK. The upper bar carrying the adjusting screw is the member insulated from the circuit breaker. *The upper bar in Model TK carries the primary current and must not be short-circuited by breaking the insulating washers, bushings or plate, nor must the circuit breaker cover be broken or checked.* The circuit breaker both inside and out must be kept scrupulously free from excess oil. (Be sure thumb nut which holds cover on circuit breaker box is tight, as this is a primary conductor to the breaker points.)



Fig. 26

Fig. 26 shows the circuit breaker of model TK. To remove the circuit breaker it is only necessary to push aside the contact spring, when the entire circuit breaker may be withdrawn.

The same care and operation of breaker bar and points must be observed as outlined for Model HK. *The breaker points must break only one-sixty-fourth of an inch.* A gauge is provided with every magneto to measure the distance. *The circuit breaker must be kept free from excess oil. Undue pressure must not be exerted in seating the two screws in the upper contact bar, so as to cause breaking or fracture of insulating washers or bushings.* If the cam does not operate the breaker bar, the adjusting screw on the contact bar is advanced too far. If the lower breaker bar does not operate freely, the screw at the lower left-hand corner of the circuit breaker has been adjusted too tight.

## Impulse Starter

- 189** — The impulse starter does away with the necessity of batteries and spark coil. The impulse starter is so designed that a catch holds the rotor in the magneto during 80 degrees of travel, then is tripped and the rotor is thrown ahead at the rate of 500 r. p. m., assuring a very hot spark which is in time with the motor.

Fig. 27 shows a view of the impulse starter.

---

## CARE AND OPERATION

---

### To Operate Starter

- 190** — By pressing down on back end of ratchet catch lock TS-8, ratchet catch TS-11 will be released and allowed to engage with notch on ratchet TS-5, which is keyed to the rotor, holding it stationary, while case TS-2 is moving 80 degrees and compressing spring TS-23. When the lug on case TS-2 moves around to release catch TS-11, the rotor is thrown ahead with a rush, causing an exceedingly hot spark to be delivered. This will continue until a predetermined engine speed has been reached, when the starter is thrown out of engagement and the magneto is driven direct through the starter coupling.

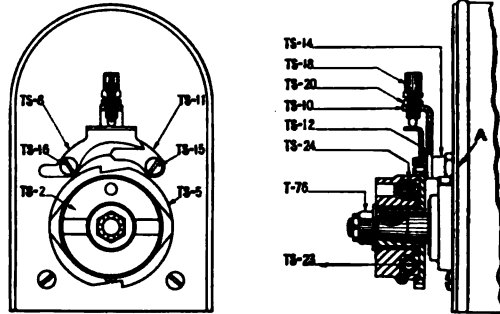

Fig. 27.

### To Replace Impulse Spring

- 191** — Remove nut T-76 and withdraw case TS-2, which will expose spring TS-23 and spring TS-24, which can then be taken out and replaced easily. On the inside of case TS-2 a lug will be found which must be inserted between the two springs when replacing case. This can be accomplished very easily by leaving spring TS-23 stick out about half way, then by setting the lug against spring and turning the case it will slide into position. To adjust the speed at which the starter throws out, loosen lock nut TS-20 and then turn adjusting screw TS-18 up or down until properly set and then lock with nut.

Keep impulse starter free from gummy oil and any foreign substance. Clean occasionally with gasoline. Oil with 3-in-1 or Household Lubricant.

### To Time Magneto to Engine

- 192** — To time magneto to engine proceed exactly as outlined for model HK in paragraph 180, page 52.

### The Distributor

- 193** — Carbon brushes are used, past which copper segment carrying the high tension current passes. Once a month clean out the distributor with a soft cloth moistened with gasoline.

### Lubrication

- 194** — *Never oil the magneto with cylinder oil, use 3-in-1 or Household Lubricant.* Make an oiler out of a piece of wire by filing a notch like a crochet

hook near the end. This will enable you to measure the oil and not guess at it. Magneto lubrication must be measured in drops. DO NOT OVER-LUBRICATE THE MAGNETO.

The oil hole near the top of the distributor provides lubrication for both the distributor bearing and the ball bearings behind the circuit breaker. *Apply three drops* of light oil once every fifteen days if running one shift only. If running double shift oil once every seven days.

The oil hole near the impulse starter feeds the ball bearings on the magneto shaft and requires but one drop every fifteen days.

Oil the wicking in the roller No. 68 once every ten days with one drop of oil and wipe excess oil away before reassembling. Oil the pin carrying the lower breaker bar with one drop of oil. Keep the breaker box scrupulously free from excess oil. *Platinum points burn out rapidly when contaminated with oil.*

## In Case of Trouble

195 — See that all nuts are tight; that the retainer spring is making good contact, and all wires leading to the spark plugs are connected or making good connections. Check up the timing to see that the magneto is timed correctly.

Look at the distributor and see that it is free from carbon dust.

Open up the circuit breaker and see that it is not flooded with oil and no oil is on the contact points. The proper adjustment for these points is one sixty-fourth of an inch apart when they break.

Examine the spring in impulse starter to determine if it is broken. If spring is broken the magneto will be put out of time.

Remove the spark plugs, examine them carefully to see that they are not cracked or short circuited and that the spark plug points are not too far apart. *The proper adjustment of spark plug points for the K-W Magneto is one sixty-fourth of an inch apart.* When the magneto has been removed for repair, always clean the spark plugs thoroughly before starting the engine again in order to be safe in detecting further trouble.

To test the magneto, engage impulse starter, pull off one secondary wire from the plug, hold it about one-eighth of an inch away from magnets and turn engine to give magneto one quick turn at the proper cylinder. A good spark should be thrown.

Frequently trouble is laid to the magneto when other parts are to blame. Be sure that compression is good, as leaky valves and poorly fitting piston rings may result in the loss of compression, thus giving rise to engine trouble that frequently is laid to the magneto. The valve rod should have the proper clearance. See Fig. 17, page 44. The carbureter may be out of adjustment or not have the proper supply of fuel due to a clogged feed pipe.

---

## CARE AND OPERATION

---

To test for a "missing" cylinder, obtain a wooden handle screw driver, place the shank of the screw driver on the valve rod and present the end close to the copper terminal on the spark plug. If a spark is present in the cylinder tested, it will be visible on the outside. Another way to determine the "missing" spark plug is to short circuit each cylinder in succession by putting the end of the screw driver firmly against the spark plug terminal and the shank of the screw driver against the valve rod.

### To Clean Spark Plugs

- 196 — To clean spark plugs, it is not merely sufficient to remove the carbon from the points, but it is necessary to disassemble the spark plug, which can be readily done, and clean the porcelain or the mica core, whichever the case may be. In case of porcelain cores, remove carbon by scraping it or with 000 sandpaper and wash clean with gasoline. Mica cores are best cleaned by lightly dressing with 000 sandpaper. Clean the interior of the spark plug by scraping and then flushing with gasoline. Reassemble plug, and be sure that all parts fit tightly. Do not force the final seating of the outer lock nut. *For successful operation of the spark plugs in using high tension current, the points should separate not to greatly exceed one sixty-fourth of an inch. THIS IS IMPORTANT.*

### Cooling System

- 197 — Cooling of the engine is effected by the circulation of water by a centrifugal pump drawing its supply past a valve from the water tank, thence into the bottom of the cylinders, out the cylinder heads and through a large vertical finned-tube radiator and thence returned to the water tank. The radiator is spring mounted to reduce vibration. Fig. 28 shows a front view of the radiator assembly.



Fig. 28. Front View Radiator.

### Radiator

- 198 — The radiator is built up with twelve sections AM 204 as shown in Fig. 29, six sections being on each side of radiator manifolds E1368 and E1588. Ten finned tubes M1688 set in two section headers comprise a radiator section. Tie rods M7311 and M7312 hold the section AM204 and the section on the opposite side of the radiator manifolds in place. Fig. 29 shows a view of radiator parts.

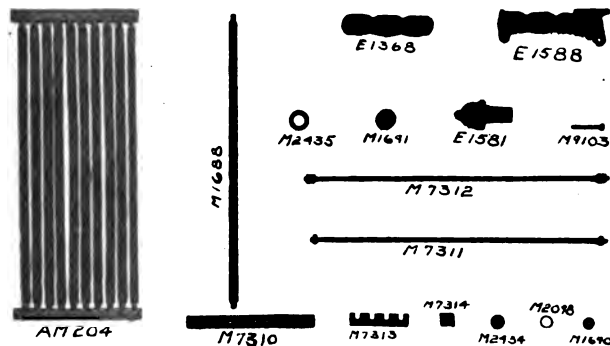

Fig. 29.

### To Drain Radiator

- 199** — To drain radiator, three brass pet cocks are provided in water manifold E1368. These pet cocks can be reached directly under radiator support frame and above the front wheel. IN FREEZING WEATHER DRAIN RADIATOR, WATER PUMP AND CYLINDERS. If it is not desired to drain the water tank underneath the frame, close valve between pump and tank before draining radiator. It is better to be on the safe side, however, and drain the tank.

### To Remove Radiator Section

- 200** — Remove radiator cover, unscrew tie rods M7311 and M7312, remove brass washers for section header M2434, containing the lead gasket M2098. It is not necessary to disturb the radiator section on the opposite side of radiator manifolds. Slip section over tie rods.

### To Repair Leaking Radiator Tube

- 201** — When radiator section has been removed from radiator, *scrape the bottom or top of leaking tube and an area around the point where the tube is set into the section header M7310 to a clean, bright surface with a knife.* Wash this surface with a solution of muriatic acid that has been cut by zinc. See paragraph 203.

### Heat Part to be Soldered with Blow Torch

- 202** — With a blow torch giving an even light blue flame and not too much pressure heat the tube on one side till the solder commences to run, then



---

## CARE AND OPERATION

---

give part heated a light brush with the acid, heat and apply wire solder to tube and flame. Regulating the presence of the flame against the tube, and directing the melting solder will aid in placing the solder and making the repair. It is unsatisfactory to attempt a repair using a soldering iron. In soldering other side be sure tube is not heated so hot that work just finished will be melted.

### Cut Acid with Zinc

- 203** — To a quantity of commercial muriatic acid add a quantity of zinc, preferably in the form of shavings. Add zinc till acid does not give off bubbles. Keep this mixture in a glass container for future use.

### Reassembling Radiator

- 204** — When reassembling radiator be sure that the lead gasket in the radiator manifold E1368 and E1588 is in good condition. If not, insert a new one. Slip section over tube. Be sure that lead gasket in brass washer for section header M2434 is in good condition. Apply washer, thread tie rod through, apply rubber gasket and tighten up snug.

If the radiator sections are kept tight on tie rods and spring mounting is kept in good order, but little trouble should occur with the radiator leaking. ALLOWING RADIATOR TO VIBRATE WILL DEVELOP LEAKS AT END OF HEADER SECTIONS OR LEAKING TUBES.

### Clean Sight Feed Glass

- 205** — In some sections of the country the water will discolor the glass, thus making it difficult to watch the circulation of the water. Where this condition occurs it is advised that the sight feed glass M1691 be removed and cleaned.

### To Drain Centrifugal Pump

- 206** — The centrifugal pump contains two brass pet cocks, the upper one of which is used to try the circulation. Open both these pet cocks and allow pump to drain. *When draining appears completed revolve flywheel by hand several revolutions to relieve any head of water that may be held in the water intake manifold.* THIS IS IMPORTANT.

### To Drain Cylinders

- 207** — Remove drain plug at bottom of cylinder water jacket on the right hand side of the engine. Protect magneto from entrance of water when draining cylinders. If the cylinders do not contain drain plug, revolving the flywheel after draining appears completed will release the head that holds water in the cylinders.

### To Drain Pipe

- 208** — The pipe from the tank to the pump contains a tee with drain cock. Open drain cock. If it is not desired to drain the tank and the valve is closed, a good precaution to take is to wrap the piece of pipe from tank to valve with cloth.

### To Refill Radiation System with Water

- 209** — Close all drain cocks. Fill water tank and start engine. As the centrifugal pump is lower than water tank it will not need priming. Water will then be pumped into cylinders and through radiator. Fill the water tank as the supply is decreased until the system will not take any more. Circulation should be established in ten to fifteen seconds. Be sure that circulating pump is operating. Open top pet cock on pump to determine if water is circulating.

### Cover Radiator in Extreme Cold Weather

- 210** — If the tractor has to be operated in extremely cold weather, it is advisable to put a sheet of canvas over the radiator screen. This canvas should be cut so that an area about the center of the radiator will admit air, and the canvas flap should be so arranged that the opening can be increased or decreased by rolling it up or down.

### Keep Radiator Cover On

- 211** — Keep radiator cover on at all times. If radiator cover gets out of repair or is allowed to shake loose, it should be repaired. It is important that the air does not gain free admission between the radiator cover and the sides of the tubes. The baffle plate should fit close to the tubes, thus causing the air to travel over the tubes instead of around the sides.

### Water Pump

- 212** — Circulation is obtained by a centrifugal pump belted to the engine and fan. The pump must be kept up to speed at all times in order to circulate the water properly. If the engine is run “idle” for any long period of time, the operator should watch the circulation very carefully.

There is very little to get out of order with the water pump. However, certain features must be watched. The bronze gland C180 shown in the Price List of Parts may not be tight enough on its packing to exclude air from gaining admission to the pump or the pump packing may be worn out and require a new packing before pump will operate properly. The pet cock in the top of the pump is used to try the circulation while the pet cock in the lower casing of the pump is used for draining purposes. After a long

---

## CARE AND OPERATION

---

period of use the bronze bushings B247 for the frame of the pump may require replacing. If the pump shaft has end play, positive circulation of the water cannot occur.

The pump pulley should be securely fastened at all times and should be positively driven by the pump and fan belt.

### Lubrication of Water Pump

- 213 — The lubrication of the centrifugal pump is effected by two grease cups. These grease cups should receive two complete turns every hour. It is best to place the lubrication so that one turn is given every half hour. Use "Caterpillar" Cup Grease in the cups. The brass gland contains an oil hole for the reception of cylinder oil. Place oil in this hole four times per day.

### Timing the Engine

- 214 — Timing the engine of the "Caterpillar" 45 is divided into two operations:
- a. Timing the valves.
  - b. Timing the magneto.

The engine of the "Caterpillar" is a four-cylinder four-stroke cycle engine, and before proceeding with the discussion of the two divisions above named it will be necessary to point out certain features in order that no mistake will be made in making the setting.

A complete discussion of engine timing is contained in Service Bulletin No. 9.

### Cycle

- 215 — A cycle is one complete set of operations occurring within a cylinder and consists of four distinct parts.
1. Admission of the fuel vapor.
  2. Compression of the charge.
  3. Explosion of the charge, or power stroke.
  4. Exhausting the burned gases.

To accomplish the above functions the piston has to make four strokes, two down and two up, and the flywheel has to make two revolutions. *With the four-cylinder four-stroke cycle engine, two power impulses are given to the crankshaft every revolution.* Fig. 30 shows a diagram of the 45 engine, and the table below shows the sequence of events per revolution, assuming that cylinder No. 1 is on the explosion or power stroke.

### Top and Bottom Centers

- 216 — In the analysis of the method of the four-stroke cycle engine the piston passes through two points called the *top and bottom centers*.
- The top center (upper dead center) is that point where the piston has*

---

**“CATERPILLAR” 45 TRACTOR**

---

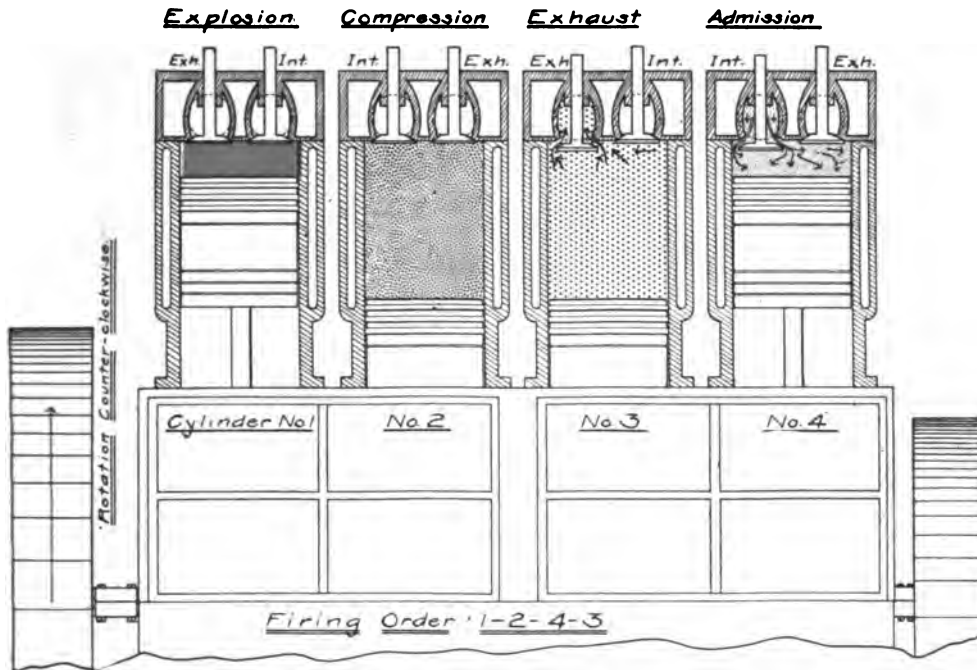

**Fig. 30. Diagram of Four-Stroke Cycle in Four-Cylinder "Caterpillar" Engine.**

### Cylinders

	1	2	3	4
1st Rev.	} Power Exhaust	} Compression Power	} Exhaust Admission	} Admission Compression
2nd Rev.	} Admission Compression	} Exhaust Admission	} Compression Power	} Power Exhaust

## CARE AND OPERATION

reached its highest point of travel towards the cylinder head. This point must be borne in mind, as from this point all 45 engines are timed.

The bottom center is that point where the piston has reached its lowest point of travel away from the cylinder head.

### Offset

- 217 — The top and bottom centers must not be judged by the apparent vertical position of the connecting rod, due to the fact that in actual construction engines are given an "offset," that is, the center line passing through the cylinder does not pass through the center line of the crankshaft. Fig. 31 is a diagram showing an exaggerated condition of "offset."

The piston has its highest point of travel upwards towards the cylinder head (top center) when the center of the crankshaft, the center of the crank pin and the center of the piston pin are in a straight line. The diagram of the engine in Fig. 33, page 67, shows the engine on top center.

This condition of offset is important to bear in mind, particularly to timing ignition and setting valves in the field. The operator must never make the mistake of setting his engine on top center by having the connecting rod in a vertical position, as the engine will be timed late. If for any reason the flywheel is not marked with top center, a cylinder head should be removed, top center determined by moving the piston in the cylinder and then marking the top center on the flywheel. From the position of top center on the flywheel project the point by means of a steel square and mark a point on the crankcase to witness the two points on a line, and use for future settings.

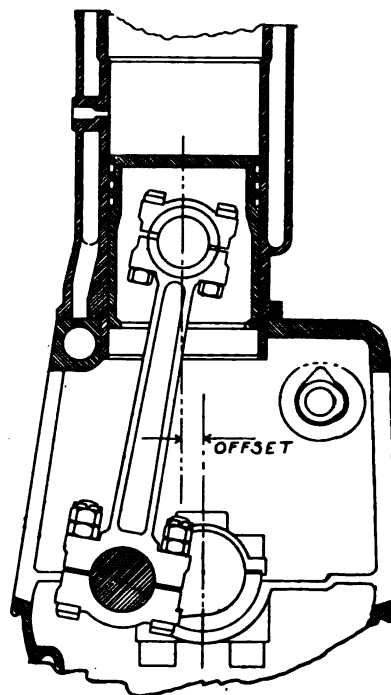

Fig. 31.

### Valve Setting

- 218 — The first requirement in timing an engine is to give all the valve rods the correct clearance of  $1/32$  of an inch over the valve stem. See Fig. 17, page 44, for the correct setting of valve rod. This setting must be made with the cam pointing down and all slack taken up between rocker arm and valve tappet. This is for the purpose of allowing for expansion and the measurements should be accurately made.

For the purpose of illustration it will be assumed that the engine has been taken down in the field and that all the gears in the gear case have been disturbed and it is desired to put the engine back on time.

*Place piston in cylinder No. 2 (second cylinder from large flywheel) on top center. With the camshaft gear engaged on the key of the camshaft but disengaged from the crankshaft timing gear, revolve the camshaft in the direction opposite to the rotation of the engine so that the exhaust cam operates the exhaust valve. Continue turning the camshaft until the exhaust valve is almost seated. This is determined by having but slight tension on the valve rod and exhaust valve (at a small fraction of movement past this point the valve rod should have its full 1/32 of an inch clearance over the exhaust valve). At this point engage the camshaft gear with the teeth of the crankshaft timing gear.*

### Timing Gears Marked

- 219** — The timing case gears of all engines are marked, usually with a letter. As a rule two teeth on the camshaft gear and only one on the crankshaft timing gear are marked. In this case the tooth on the crankshaft gear should mesh between the two marked teeth on the camshaft gear.

Some engines contain but one mark on the camshaft gear, always placed between two teeth, and the crankshaft gear similarly marked. In this case the gears should be meshed so that the two marks will come directly in line.

### Magneto Gear Not Marked

- 220** — The teeth on the gear that operates the magneto are not marked and the magneto is put on correct time by revolving it independently of the magneto shaft (by having the Oldham coupling disengaged) and setting it where required.

### Do Not Change Timing of Engine

- 221** — The point at which the lettered or marked teeth on the camshaft and crankshaft timing gears engage should not be changed so as to make the timing either early or late, as such change will affect the horsepower considerably and in addition is a fertile source of overheating engine.

### Valve Setting

- 222** — *a. Fig. 32 gives a diagram for the valve opening and closing of a 45 engine, and shows the actual duration of the different strokes. When the piston is passing through top or bottom center, it is practically at a standstill, during which time the crankshaft, however, is in uniform circu-*

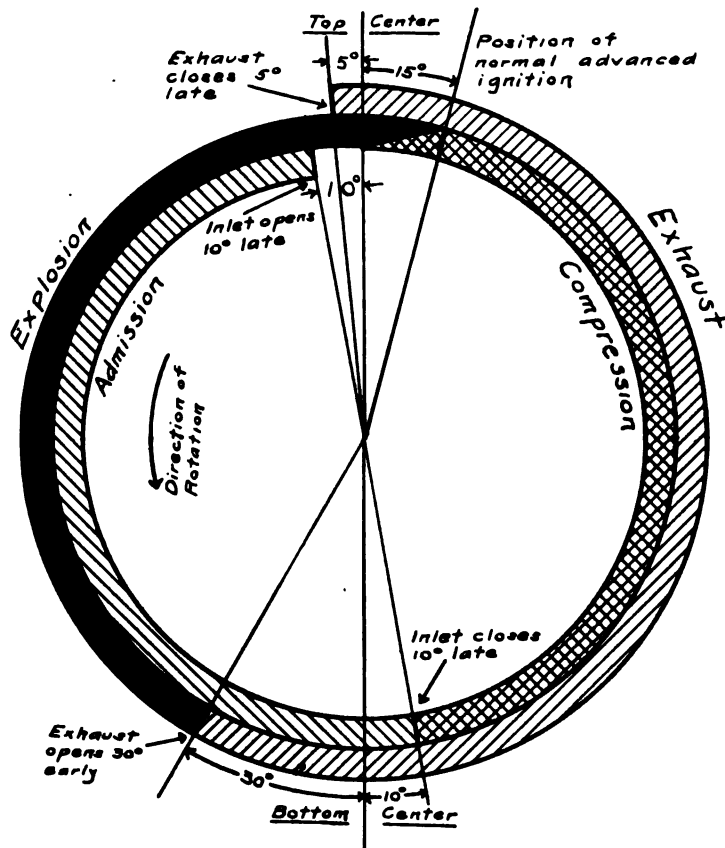

Fig. 32.

Theoretically, each separate operation of admission, compression, explosion and exhaust in the four-stroke cycle engine is supposed to begin and end at top or bottom center, though in actual construction this is not true. If the valve opens before center is reached, the valve is said to open early; if the valve closes after center has been past the valve is said to close late.

The early and late closing of the valves is governed by the cam positions on the camshaft and cannot be changed by the operator.

The point to be observed in valve setting is to have the valve rods with their correct clearance, 1/32 of an inch, and the camshaft timed by revolving the camshaft gear until the exhaust valve on cylinder No. 2 is just about closed, which point is determined by trying the tension on the valve rod and rocker arm.

lar motion. The piston travels faster in certain portions of the stroke (due to the fact that it has to come to a dead stop at each end of the stroke and reverse direction); consequently this fact is taken advantage of in cam mounting, for if the valves are allowed to remain open during certain overlapping periods the gases will be swept in or out of the cylinder by their own momentum, thus aiding the function of the engine.

## Magneto Timing

223 — b. When the valves have been correctly timed, proceed to time the magneto as outlined in paragraph 180, page 52, describing the HK Magneto

and time. It is possible to time the magneto to any cylinder by getting the correct firing order and making contact with the correct segment. All "Caterpillar" engines fire 1-2-4-3, and the magneto distributors are numbered 1-2-3-4. These do not refer to the cylinder numbers, however, and it is necessary to interchange the leads from the distributor so that lead No. 3 goes to cylinder No. 4 and lead No. 4 goes to cylinder No. 3. Fig. 33 shows a diagram of the piston of the engine on top center of compression stroke and the model TK Magneto placed in full retard.

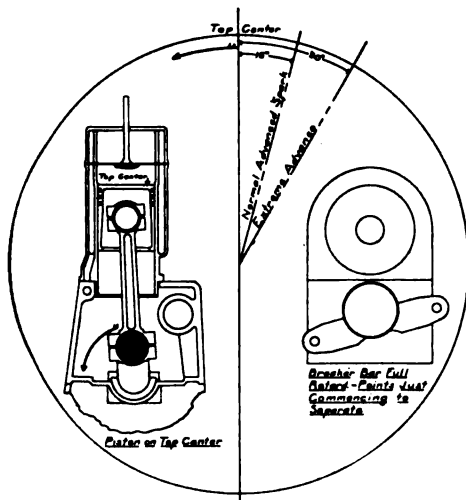

Fig. 33.

The position of the circuit breaker arm for the Model HK is exactly the same. Assuming that the Oldham coupling is disengaged, rotate the magneto in the same direction that the engine turns till the copper segment is making contact with the cylinder to be timed. Then slowly rotate the free end of the Oldham coupling till the circuit breaker points are just commencing to separate. *This is the firing point of the magneto.* Connect the Oldham coupling in the holes that coincide and proceed to start the engine. The engine will then fire on top center when the circuit breaker is in full retard. Ad-

vancing the ignition to the point where the engine works best will be at a point toward 15 and 30 degrees ahead of top center with 30 degrees of advance as the extreme range. If the engine should knock on extreme advance spark, retard the spark to the point where the engine works without a knock.

## Engine Overheating

**224** — The efficiency of the internal combustion engine is dependent upon the amount of heat derived from the heat generated by the explosion of the fuel vapors. Not all of the heat units derived from the explosive mixture are utilized in work. The object of the cooling system is to keep the temperature of the cylinders below the danger point but at the same time keep it as hot as possible to secure the maximum power. If no cooling medium were provided, the heat of the continuous series of explosions, each of which is over 2000 degrees Fahrenheit, would soon heat the metal parts of the engine to the point where they would seize and render further operation of the engine impossible. The object of the cooling system is to get rid of the surplus heat. All "Caterpillar" engines are water cooled. Circulation is



---

## CARE AND OPERATION

---

maintained by means of a centrifugal pump. An overheating engine can be caused by

- 1st. Failure of radiation system to perform proper functions.
- 2nd. Lack of efficient lubrication.
- 3rd. Incorrect mixture in carbureter. Over-lean and over-rich mixtures.
- 4th. Air leaks that dilute mixture after passing spray nozzle.
- 5th. Incorrectly timed valves.
- 6th. Ignition of fuel charge at wrong time.
- 7th. Presence of carbon deposit in combustion chamber.

1st—Failure of radiation system to perform proper functions can be divided into

- a. Poor radiation. Clogged circulation system.
- b. Failure of pump. Slipping pump and fan belt.
- c. Radiator fan out of repair.
- d. Water jackets in cylinders clogged with sediment.
- e. Leakage in radiator sections or auxiliary water tank.
- f. Glands on centrifugal pump leaking air to system.

2nd—Lack of efficient lubrication can be divided into

- g. Poor or wrong quality oil used.
- h. Dirty oil in crankcase—clogged oil circulation system.
- i. Incorrect oil levels. Dippers on connecting rods not dipping deep enough.
- j. Engine not up to speed.
- k. Crankcase oil supply thinned by entrance of fuel particles from over-rich mixture, or continuous “missing” of cylinder.

3rd—Incorrect mixture in carbureter can be divided into

- l. Over-rich mixture.
- m. Over-lean or thin mixture.

4th—Air leaks that dilute mixture after passing spray nozzle can be divided into

- n. Worn throttle shaft.
- o. Leaking intake manifold.
- p. Leaking intake manifold gaskets.
- q. Leaking intake valve stem guides.
- r. Leaking auxiliary air devices.

5th—Incorrectly timed valves can be divided into

- s. Incorrectly timed camshaft.
- t. Improperly adjusted valve rods.

A badly carbonized engine will not only cause overheating but will cause pre-ignition as well, with its resultant evil effects, even though the magneto is correctly timed. A badly carbonized engine should receive attention and the carbon and its cause removed. A full discussion of carbon and carbon trouble is contained in Service Bulletin No. 5.

### Removal of Scale

- 225** — To remove scale, dissolve about six pounds of common washing soda in five gallons of boiling water and introduce this mixture directly into the circulating system. The tractor should be worked one day with the soda solution in it and then the entire system should be drained and flushed with clean water. Particles of scale may become disengaged and not completely dissolved and it will be necessary to make sure that all loose scales are removed. If convenient to a pressure system, the hose connections should be removed and clean water under pressure should be forced through the water inlet manifold as well as the radiator. The radiator can readily be disassembled if it is necessary to clean out disengaged scale.

A full discussion of the subdivisions on engine overheating is contained in Service Bulletin No. 8.

### Troubles

- 226** — When an engine refuses to start, stops or misses, do not immediately start to work with the wrenches, but sit down and analyze the problem thoroughly. By doing this, much valuable time will be saved. Sometimes the trouble is with the operator.

### If Engine Fails to Start

- 227** — (1) *Lack of fuel.*

See that needle valve is turned on from one to one and one-quarter turns, and that shut-off cock in the fuel line is turned on. Screen in vacuum tank may be clogged. Reservoir in vacuum tank may be empty. Distillate tank may be empty.

- (2) *Lack of ignition current.*

Be sure magneto control throttle lever has been advanced so that the short circuiting switch on the magneto is disengaged. If an independent switch for Model HK K-W Magneto is used, be sure that it is not "shorted"; this is a common fault. Be sure that all cover nuts on the distributor side of the magneto are seated tightly. See paragraph 178. *Be sure that insulating washers on the lower contact bar are not broken.* See paragraphs 175 and 188. Be sure that circuit breaker box is not flooded with oil inside or out. See paragraph 177. Be sure that circuit breaker points break only 1/64th inch. Examine impulse starter for broken spring. *In foggy weather wipe distributor dry on the outside with a clean cloth.*

---

## CARE AND OPERATION

---

(3) *Dirty spark plugs.*

Spark plug points too far apart. See paragraph 196. Most operators make mistake in not keeping gap about 1/64th inch wide. In extremely cold weather wet end of spark plug with gasoline after cleaning and before inserting in cylinder head.

(4) *Priming engine.*

DO NOT OVER-PRIME ENGINE WITH GASOLINE. Over-priming will wash lubricating film off piston and cylinder, thus causing loss of compression. See paragraph 16, page 3. Be sure that you are priming with gasoline and not distillate or kerosene. If an engine has been repeatedly primed and compression is lost, remove spark plugs and pour one-quarter cup of cylinder oil in each cylinder and revolve engine several times by hand to re-establish compression. Prime cylinders with least quantity of gasoline, but prime carbureter heavy if desired.

(5) *Valve rods may not have proper clearance.*

When the cam is pointing downward for the particular valve examined and all slack taken up from rocker arm to valve tappet, the rocker arm should have 1/32nd inch clearance over valve stem. See paragraph 154 and Fig. 17, page 44.

(6) *Air leaks above carbureter.*

Air leaks above carbureter may make difficult starting. Butterfly shaft should not leak air. Intake manifold gaskets should not leak air. See paragraph 151, page 41. Intake valve stem guides should not leak air. See paragraph 151 and Fig. 14, pages 41 and 37.

(7) *Lack of compression.*

Valves may need grinding.

## Engine Stops

228 — (1) *Lack of distillate.*

Vacuum system tank may be clogged. Water present in carbureter or vacuum tank.

(2) *Carbureter flooded.*

Float valve stuck. Float may be soggy. Carbureter may be improperly adjusted.

(3) *Cover Nut No. 79 may be loose on magneto.* Magnetos have been returned to factory for repair when it was not possible to start engine, when all repair necessary was to tighten cover nut. Other nuts may cause trouble by being loose. Roller No. 68 may be worn on bushing, or steel tire may be loose, thus interfering with breaking of points by causing bind.

(4) *Lack of lubrication.*

Oil level under cylinders may be low. Oil reservoir may be empty. Rotary oil pump or sight feed distributor may be clogged. *Engine may not be up to speed, thus rendering splash lubrication ineffective to reach pistons and cylinders.* Oil screen may be clogged.

(5) *Lack of circulation.*

Pump and fan belt may be slipping on pulleys. Pump and fan belt may be improperly laced. Clipper lacing is recommended. Fan may be out of repair. Brass glands on pump may be admitting air. Rubber particles may be clogging system. Scale may be present in circulation system. Sediment may be present in water jackets, thus impairing circulation. Examine water jackets for sediment every time that a cylinder head is removed and remove if necessary. Sufficient water may not be present in water tank.

## Engine Misses

229 — (1) *Fouled spark plug.*

Short circuit spark plugs by using wooden handled screw driver and short circuit spark plug terminal to valve rod. When one or more spark plugs are reached the short circuiting of which makes no difference in the engine's operation, remove and clean. See paragraph 196 for correct method of cleaning spark plug.

(2) *Points of spark plugs improperly set.*

Points of spark plug should separate 1/64th of an inch. A wide gap will make a “missing” cylinder.

(3) *Roller No. 68 in circuit breaker may be worn.*

*The roller in circuit breaker bar No. 190 should revolve true to give even break on points.* Test separation of points by revolving flywheel several times and watching action of roller and points.

(4) *Defective carbureter adjustment.*

See paragraphs 156 and 157 for adjusting carbureter; see also Service Bulletin No. 6.

(5) *Loss of compression.*

Valve may be stuck, or particle of carbon may be imbedded under exhaust valve. Valves may need grinding. Valve rods may be out of adjustment, causing incorrect opening and closing of valves. Piston rings may be worn against cylinder, allowing compression to pass by. Piston rings may be worn in slot, allowing too much vertical movement, thus allowing products of combustion to pass around the piston ring. Cylinders may be worn out of round due to dust entering through carbureter. Dry air cleaner should be used at all times to prevent wear on cylinders.

(6) *Valve may be stuck open.*

Particularly when new, valve stems should receive generous lubrication—  
one-half kerosene, one-half cylinder oil.

(7) *Water in distillate.*

Water in the distillate is indicated by the engine running in a sputtering  
fashion. Drain the carbureter and drain the reservoir in the vacuum tank.

### Loss of Power

230 — (1) *The engine will run but will not pull under heavy load.*

The carbureter may be out of adjustment. If black smoke is present in  
exhaust gases, cut down fuel till pop-back does not occur and exhaust gases  
are clear. For heavy load it may be necessary to advance the needle valve  
a fraction of a turn in addition. The mixture may be overlean, indicated by  
pop-backs in carbureter. Increase fuel or increase the tension on the air  
valve spring. The carbureter may be flooded or float stuck. Butterfly or  
throttle shaft may be worn, admitting air; intake manifold gaskets or valve  
stem guides may be leaking air, thus making it impossible to secure an ac-  
curate carbureter adjustment. Usually the engine will overheat if air leaks  
occur above carbureter.

(2) *Governor may not be in adjustment.*

*When throttle control on steering wheel is placed at the top of the quad-  
rant the levers to the governor and carbureter should allow the butterfly  
valve to open full.* Adjust set screw collars so that when engine is stopped  
and throttle lever full open the butterfly shaft will be full open. See para-  
graph 144 for correct governor adjustment.

(3) *Valves not seating properly.*

Valve rod should have  $1/32$  of an inch clearance over valve stem. See  
Fig. 17 for correct adjustment. Particles of carbon may be imbedded under  
exhaust valve, not allowing valves to close completely to retain compression.  
Valves may need grinding.

(4) *Weak ignition.*

Magneto may be fouled with cylinder oil and dirt and not giving its  
proper spark.

(5) *Lack of oil.*

Lubricating oil may be too low. Oil may be of incorrect body.

(6) *Carbureter may be improperly adjusted.*

Cork gasket between top of carbureter and bottom of flange carrying the  
butterfly shaft may be leaking, or may not be replaced after having carbur-  
eter off for inspection. Hinge on float lever may be worn. Needle valve  
may have shoulder worn on it, or spray nozzle expanded too far by forc-  
ing needle valve to seat when stopping engine.

“Pop-back” in carbureter is usually due to over-lean mixture. Increase  
fuel, decrease air. Pop-backs may also be caused by valve rods being im-  
properly adjusted, opening inlet valve before top center is reached and ex-  
haust valve is closed. Inlet valve may be stuck open.

(7) Cylinders may be worn so badly by the entrance of field or road  
dust that good compression cannot be obtained even with new, accurately  
fitted piston rings.

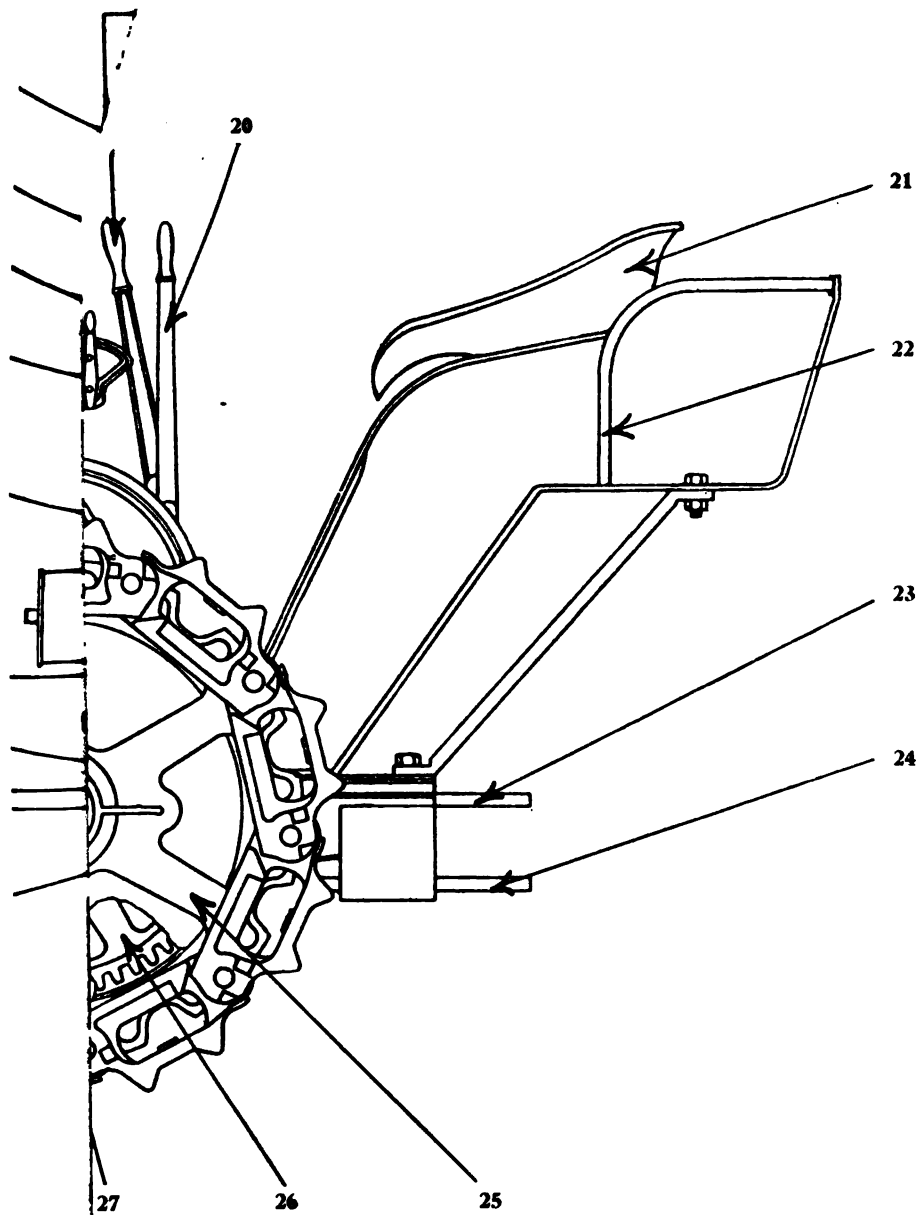

Do Not  
Remove

1-49 (rev 8/85)

locking nut

idler roller bracket

idler

idler

shoe

46—Water tank

47—Starting handle

48—Pump pulley

49—Stationary pulley clutch

50—Spring mount for radiator

51—Pump and fan belt

52—Belt idler pulley

53—Belt idler pulley bracket

1. The first part of the document discusses the importance of maintaining accurate records of all transactions and activities. It emphasizes that this is crucial for ensuring transparency and accountability in the organization's operations.

2. The second part outlines the various methods and tools used to collect and analyze data. This includes both traditional manual methods and modern digital technologies, highlighting the benefits of automation and data-driven insights.

3. The third part focuses on the challenges and risks associated with data management, such as data security, privacy concerns, and the potential for data loss or corruption. It provides strategies to mitigate these risks and ensure the integrity of the data.

4. The fourth part discusses the role of data in decision-making and strategic planning. It explains how data analysis can help identify trends, opportunities, and areas for improvement, leading to more informed and effective business decisions.

5. The fifth part covers the importance of data governance and compliance with relevant regulations and standards. It outlines the key principles of data governance, including data quality, access control, and retention policies.

6. The sixth part addresses the future of data management, including emerging trends like artificial intelligence, machine learning, and cloud-based data solutions. It discusses how these technologies will shape the way organizations handle their data in the coming years.

7. The seventh part provides a summary of the key findings and recommendations from the document. It reiterates the importance of a robust data management strategy and offers practical advice for implementing such a strategy.

8. The final part of the document includes a list of references and a glossary of key terms. This section is designed to provide additional resources for readers and ensure that all terminology is clearly defined.

## Engine Overheating

- 231 — For a complete list of overheating causes, see paragraph 224, page 67.  
For a complete discussion of engine overheating, see Service Bulletin No. 8.

## Engine Knocks

- 232 — (1) Connecting rod bearings may be too loose.  
(2) Crankshaft bearings may be loose. Try bearings only when engine is hot, as oil is then thinned to operating conditions and slack is not absorbed by oil film.  
(3) If knock is in crankcase and knock cannot be found, try crankshaft for a low bearing.  
(4) Lack of proper lubrication.  
(5) Magneto may be timed too early.  
(6) Engine may be operated with spark advanced too far when magneto is correctly timed.  
(7) Carbon in combustion chamber causing pre-ignition of fuel vapor.  
(8) Carbureter may be adjusted for normal load conditions and when engine reaches a particularly hard spot “pinging” occurs. Increase fuel. See paragraph 87, page 21.  
(9) Overheating, due to lack of circulation water.

## Starting and Stationary Assembly

- 233 — Fig. 35 shows the view of the starting and stationary pulley assembly.

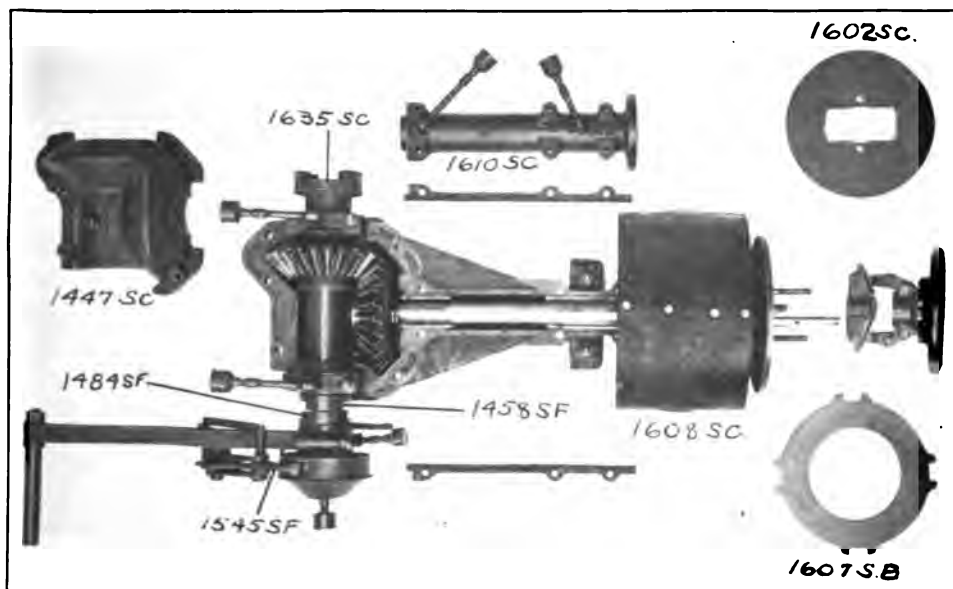

Fig. 35

1447SC—Gear Case Cover  
1484SF—Jaw Clutch Ratchet  
1458SF—Clutch and Journal

1545SF—Pawl  
1602SC—Female Friction  
1607SB—Male Friction

1608SC—Belt Pulley  
1610SC—Bearing Cap  
1635SC—Coupling



## To Start Engine

- 234** — Release the sliding catch on the right-hand corner of the tractor frame that holds the starting crank up and to the side. Let the crank as far down as it will go, then engage pawl 1545SF with the ratchet and revolve engine. The operator should be careful not to let the engine revolve back through part of the revolution when he is getting a new position on the pawl and ratchet. When the engine is coming up on a compression stroke, the operation should be quick, *and when the end of the compression stroke is nearly reached give the engine a positive quick flip past center.* Allowing the engine to rock back makes hard starting.

## Stationary Pulley

- 235** — *For straight running the stationary pulley assembly is never engaged.* Only when stationary work is wanted should the stationary pulley assembly be placed in gear. The stationary pulley assembly is out of gear when the condition exists that is shown in Fig. 35—that is, clutch 1484SF is not engaged with the clutch 1458SF.

## To Place Stationary Pulley Assembly in Gear

- 236** — Release the starting crank from the sliding catch on the frame and drop into position as if to start the engine; then shove the starting crank assembly and clutch towards the engine until the two clutches are in mesh. A finger on the extreme end of the starting crank engages in a slot to hold the two clutches in gear. This same finger holds the clutches out of gear by being engaged in the slot farthest away from the engine. The engine can be cranked in both positions of the clutch.

(NOTE.) The stationary assembly can only be put into gear when the engine is not running.

To facilitate engaging the two clutches to put the stationary pulley assembly into gear, shove the clutch of the stationary pulley shown at the extreme right of Fig. 35 to "in" position, then revolve the stationary pulley assembly by grasping the stationary pulley by the two hands and revolving till the two clutches are in the proper position to mesh.

The stationary pulley can run idle when the balance of the stationary pulley assembly is revolving. This condition is obtained by pulling the clutch located inside the stationary pulley to "out" position. A grease cup is provided for the stationary pulley bearing; it is inside the pulley towards the engine.

## Lubrication

- 237** — The starting crank and stationary pulley assembly contains six grease cups. The three grease cups that have to receive two turns per hour under all conditions of operation are the ones that are shown on the end of the starting crank towards the right, and the grease cup at the end of the crankshaft extension shown at the bottom of the figure, and the grease cup that is shown next to the starting crank on the case just above the starting crank. The three grease cups on the main assembly, one being shown near

the clutch 1635SC and two on the long bearing cap 1610SC, do not need to be turned up except when the stationary pulley assembly is in gear. All grease cups should receive two turns per hour when the stationary assembly is in gear. The grease cup inside the pulley should receive a couple of

turns per hour if pulley idles much.

The gear case on the stationary assembly should be filled one-quarter full with “Caterpillar” Transmission Oil. If the case is empty the required quantity would be about three pints. The transmission oil is inserted to the gear case through the plug shown on the top of the cover 1447SC.

**IMPORTANT:**

Whenever stationary work is being done, give oil cup in master clutch one turn per hour. See paragraph 246a. Do not engage master clutch and revolve transmission in “neutral.” See paragraph 239a.

**Master Clutch**

Fig. 36 shows the cross section of the master clutch for “Caterpillar” 45 Tractor. Fig. 37 shows the side view of the different parts of the

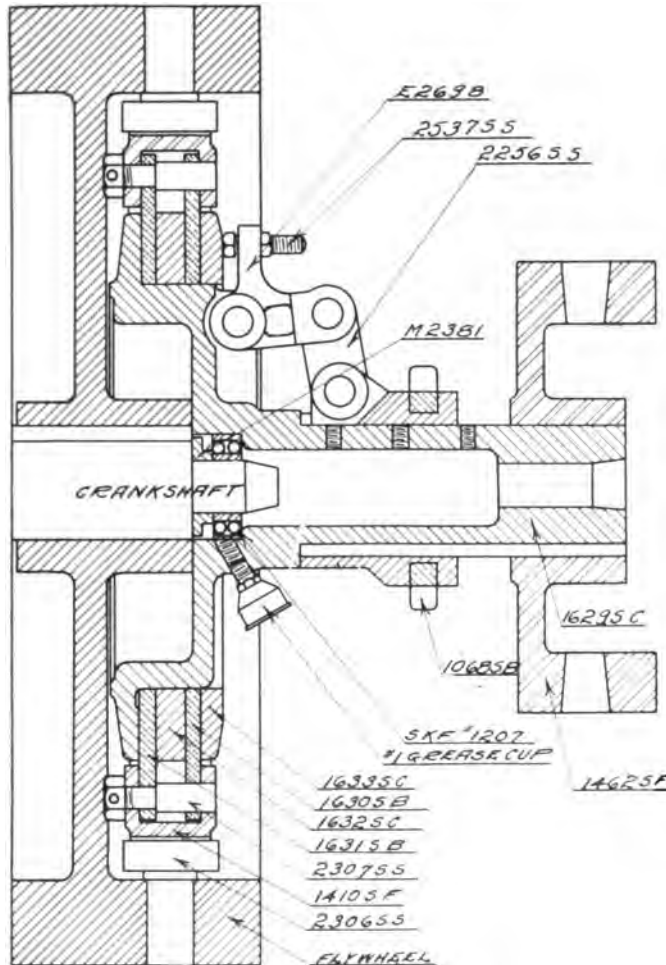

**238** —

**Fig. 36**

- |                               |                        |
|-------------------------------|------------------------|
| E2698—Dog                     | 1633SC—Female friction |
| 2537SS—Adjusting screw        | 1630SB—Male friction   |
| 2256SS—Link                   | 1632SC—Female friction |
| M2381—Washer                  | 1631SB—Male friction   |
| 1629SC—Female friction        | 2307SS—Special bolt    |
| 1068SB—Shifting ring          | 1410SF—Retaining link  |
| 1462SF—Main friction coupling | 2306SS—Pin             |

master clutch for the 45 tractor. The clutch contains two bronze discs, 1630SS and 1631SB, which are the driving members of the clutch, and are secured to the flywheel by the bolt 2307SS, the pin 2306SS, and the retaining ring 1410SF. The friction surfaces on parts 1629SC, 1632SC

---

**CARE AND OPERATION**

---

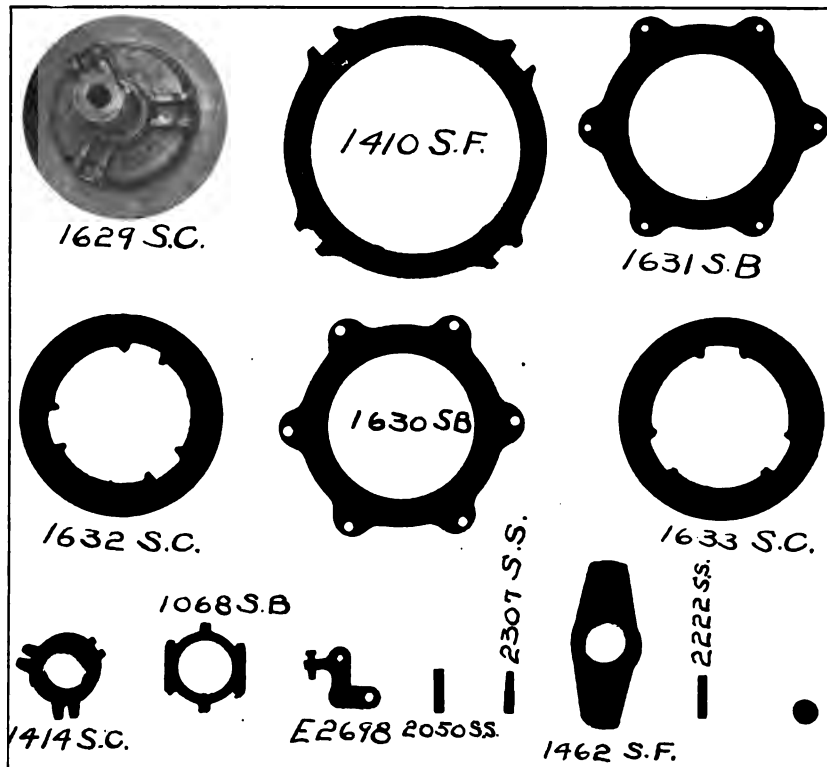

Fig. 37

and 1633SC compose the balance of the clutch, and are considered the driven members.

The clutch number 1629SE, which carries the clutch throughout collar and friction discs, rise from the crankshaft on a number 1207SKF ball bearing. From the end of the female friction 1629SE is carried as the main friction coupling for the universal coupling.

### Adjusting the Master Clutch

- 239** — When the master clutch does not hold, or when it binds in one part and heats, it indicates that the master clutch is not in adjustment. The master clutch adjustment is secured through three set screws 2537SS.

To make the proper adjustment of the master clutch, release the lug nuts and back off the set screws 2537SS. Throw the master clutch lever near the driver seat to "IN" position; then bring up the three set screws 2537SS firmly with a wrench without forcing the threads. Set the lug nuts up firmly. This gives a good starting place. If the clutch does not hold with this adjustment, the following additional adjustment should be very accurately made.

With the master clutch “IN” position, back off lug nuts from three set screws 2537SS, then throw master clutch to “OUT” position and advance set screws 2537SS to one-sixteenth of a full turn; then set lug nuts. The master clutch should be adjusted by trial so that it will not bind when released and will hold firmly when engaged.

**239a**— **IMPORTANT:** *Do not leave master clutch “IN” with transmission gears in neutral position for more than few minutes at a time.* The large gears that carry oil up to crankshaft extension No. 2 are not revolving, and insufficient lubrication would cause trouble with the bearings. See paragraph 246a.

If the clutch tends to heat and drag while disengaged from transmission, the condition is caused by

(1) Set screws for adjusting clutch being too tight, or else one particular set screw is adjusted too tight.

(2) Clutch full of gummy oil and dust. Flush out with distillate.

(3) Brake shoe on universal ring not properly adjusted. See paragraph 243.

### Lubrication of Master Clutch

**240** — With the master clutch thrown to “OUT” position, put a couple of squirts of cylinder oil with the oil can on the friction surfaces of the bronze and castiron friction members about twice a day. Experience will be the best guide in the amount of oil to apply to the friction surfaces. However, be careful not to over-lubricate this part. It is advisable at intervals to flush the master clutch friction plates with distillate or gasoline to cut any gummy residue that may be left by the oil. Keep shifting ring 1068SB oiled thoroughly; give grease cup two turns per hour.

On the master clutch is located a No. 1 grease cup which feeds cup grease directly on the SKF roller bearing. While this roller bearing does not require much lubrication, yet if the tractor is used on stationary work and the main clutch not engaged, it is advisable to give the grease cup about one turn per hour. If the tractor is used for straight running, pulling implements, give this cup one turn twice a day.

Oil the friction dog pins with cylinder oil once a day. Oil the bronze throw-out collar 1068SB with cylinder oil once an hour.

### Care of Master Clutch

**241** — Bronze and cast steel discs should be lubricated to prevent wear and cutting. The pin 2307SF and the lug 1410SF should be kept in adjustment so that wear will not occur and wear oblong holes in the bronze discs. The SKF ball bearing must receive its correct supply of cup grease, and this point must be particularly watched if the engine is doing stationary work. The master clutch should not seize or bind or heat. If it does, one of the three set screws 2537SS is bearing harder than the balance.

## Universal Coupling and Brake

243 — Fig. 38 shows a view of the universal coupling, together with the brake

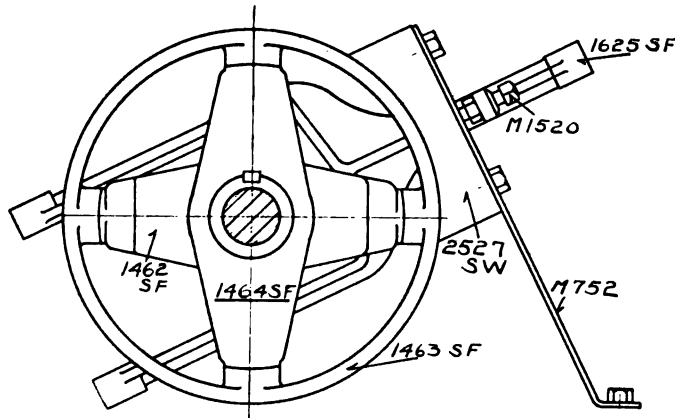

Fig. 38

2527SW for the universal ring. The part 1464SF is the coupling journal that extends from the universal ring inside the front bearing of the transmission and through which crankshaft extension No. 2 extends. The universal coupling is located between the master clutch and the transmission.

When the master clutch lever, Fig. 36, is operated so as to disengage the master clutch, the set screw M1520, Fig. 38, which is attached to the shifter fork 1625SF, slides over the back of the brake 2527SW and causes the brake to engage with the universal ring and stops the spinning of the free part of the master clutch and the transmission gears when it is desired to shift gears. The set screw M1520 should be kept in adjustment so that the gears will be stopped from spinning when the master clutch is disengaged.

In time the wood brake block 2527SW will wear and may necessitate renewing. A piece of brake lining applied to this wooden brake block when it has worn sufficiently and securely fastened makes a very convenient and durable repair.

## Transmission

244 — Fig. 39 shows a view from the top of the transmission of the "Caterpillar" 45 Tractor. Power is transmitted from the coupling journal 1464SF to the gear 1465SF. Crankshaft extension No. 2 extends unbroken from the outer edge of the coupling journal 1464SF to the bevel pinion 1472SS. Crankshaft extension No. 2 contains two feather keys over which the double clutch 2282SS operates. For direct drive the double clutch M5124 is engaged with the clutch on gear 1465SF. For low gear work the double clutch 2283SS is engaged with the gear 1471SF. From the coupling journal the power is transmitted through the gear 1465SF to a change speed shaft lower down in the transmission and then by another gear is transferred to gear 1471SF.

## ‘‘CATERPILLAR’’ 45 TRACTOR

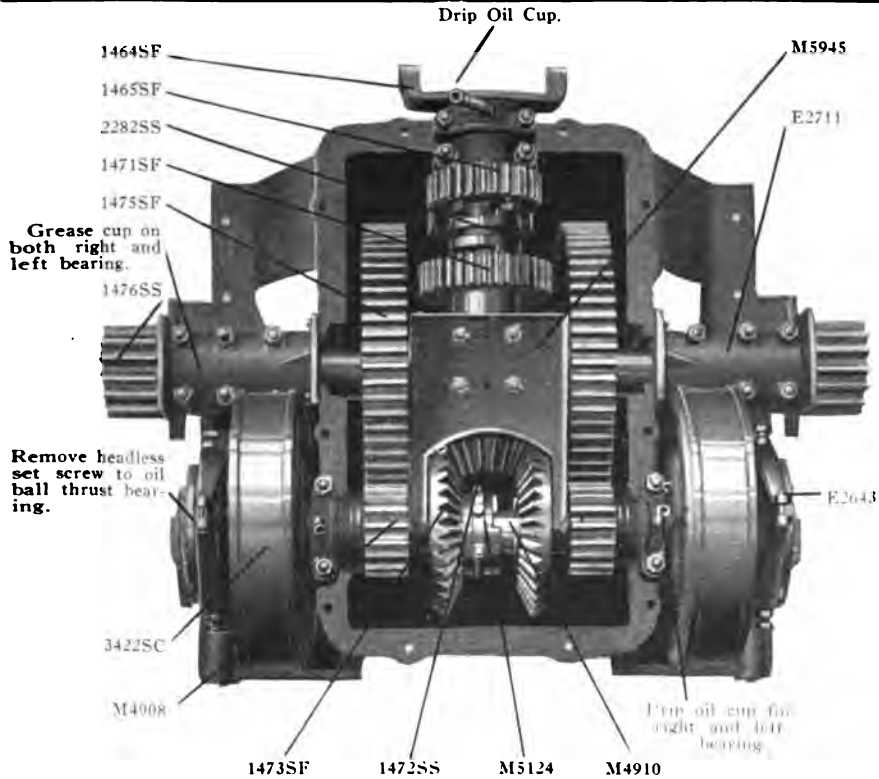

**Fig. 39**

- |                         |                           |                                |
|-------------------------|---------------------------|--------------------------------|
| 1464SF—Coupling Journal | 1476SS—Drive Spur Pinion  | M5124 —Double Clutch           |
| 1465SF—Spur Gear        | 3422SC—Housing            | M4910 —Shaft                   |
| 2282SS—Double Clutch    | M4908 —Spur Pinion        | E 2643 —Shifting Fork          |
| 1471SF—Clutch Gear      | 1473SF—Bevel Gear         | E 2711 —Intermediate Shaft Cap |
| 1475SF—Spur Gear        | 1472SS—Bevel Drive Pinion | M5945 —Oil Pan                 |

### Shifting Positions

**245** — Fig. 40 shows the shifting positions for the ‘‘Caterpillar’’ 45 Tractor.

For direct speed shove shifting lever *straight ahead* from neutral position and then press lever to the right. For low speed, if the operator has the shifting lever in direct, *pull the lever straight back*. From neutral, low is obtained by pulling the lever straight back and then pressing towards the right till the mesh occurs. The operator should remember that *pressing the lever towards the right will engage the go-ahead gears*.

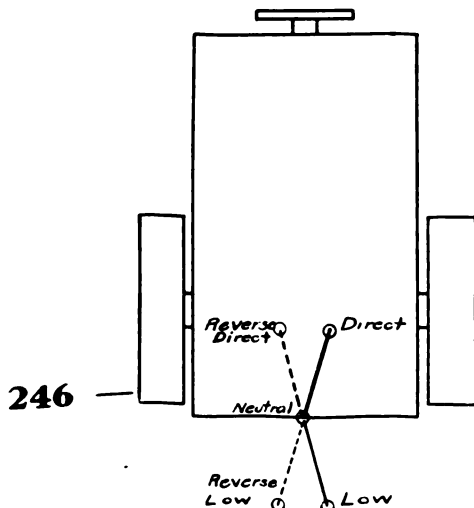

**Fig. 40**

### Reverse

Two positions can be secured for reverse—reverse low and reverse direct speed. Reverse is secured by pressing the lever towards the left. Reverse direct is straight ahead and press lever to left. Reverse low is straight back and press lever to left.

---

## CARE AND OPERATION

---

**IMPORTANT:** To aid in shifting the gears and securing the proper mesh, it is necessary to revolve the master clutch for a fraction of a turn. *With the left hand holding the shifting lever and pressing in the desired direction, advance the master clutch lever with the right hand to engage the master clutch and cause it to revolve slowly till the gears mesh.*

*If all gears are in neutral it is not possible to shift directly into reverse until the direct or low gears have been engaged first. Refer to Fig. 43. Pressing the shifting lever to the right or the left engages the double clutch M5124 with 1473SF right or 1473SF left. Drawing the shifting lever forward engages the direct gear and backwards engages the low. To shift the double clutch M1524 from one side to the other and to secure mesh, it is necessary that the bevel pinion 1472SS revolve the gears 1472SF.*

- 246a— Caution:** *If the engine is used for stationary work, do not engage the master clutch and revolve the transmission in neutral position except for very short intervals. Refer to Fig. 39. To lubricate crankshaft extension No. 2, it is necessary for gears 1475SF to carry the oil up and deposit it in the pan M5945. If the crankshaft extension No. 2 is revolved in neutral, the gears 1475SF are not being revolved and the shaft is not receiving lubrication.*

### Bearings and Oil Grooves

- 247 —** Fig. 41 shows a view of the bearings in a "Caterpillar" 45 Transmission. A and B are the bearings for the steering clutch assembly, and attention

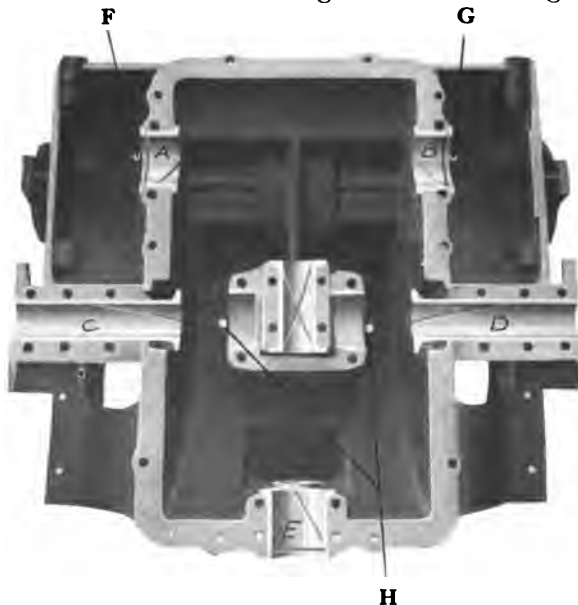

**Fig. 41 — Drain Plugs**

is directed to the fact that the diagonal oil grooves converge towards the operator and the extreme inner edge of the bearing is cut away to allow the return of the oil to the transmission, thus preventing leaks to the outside. In addition the bearings are tunneled underneath and the oil that collects in the outer oil groove is allowed to return to the transmission. Drip oil cups are used on these bearings. The oil grooves in the long bearings C and D converge away from the operator. The inner edge of the babbitt on these bearings, as well as A and B, are cut away to allow the return of the oil to the transmission. Grease cups are used on the outer edge of these bearings.

Bearing E, which is the front bearing of the transmission, is grooved so that the oil being churned by the gear 1465SF, Fig. 41, will exert a suction effect on the diagonal groove and thus prevent oil leaking to the outside of the transmission case. This bearing is also tunneled and the outer oil groove tapped to return oil to the transmission. A drip oil cup is used on this bearing.

Oil drains are provided, as shown at F and G, to drain oil away from the steering clutches. These oil drains must be kept open.

All bearings in the transmission are poured with Armature Metal, made to “Caterpillar” specifications.

### Oil Plugs

- 248** — Plugs are provided in the right and left half bottom of the transmission, as shown at H, Fig. 41, to drain the oil from the transmission. The transmission should be drained at least once every ninety days, washed out with kerosene, and new transmission oil replaced.

### Lubrication of Transmission

- 249** — Fig. 42 shows a general outside view of the transmission, steering shaft and track drive sprocket of the “Caterpillar” 45 Tractor. *The transmission*

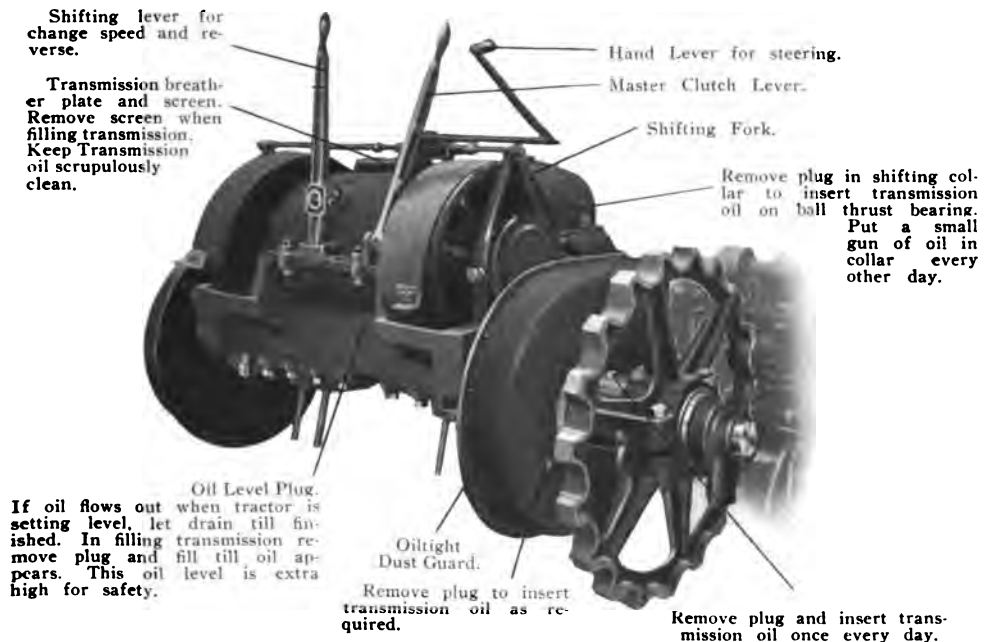

**Fig. 42**

*of the 45 tractor must be lubricated at all times with a straight mineral transmission oil. “Caterpillar” Transmission Oil has been especially developed for all transmissions of “Caterpillar” Tractors, and its exclusive use is recommended on account of the service that it gives.*



(CAUTION.) UNDER NO CIRCUMSTANCES MUST THE 45 TRANSMISSION BE LUBRICATED WITH A SEMI-FLUID GREASE, OR A MIXTURE OF CYLINDER OIL AND CUP GREASE, OR ANY OTHER TRANSMISSION COMPOUND. A STRAIGHT FLUID MINERAL OIL IS THE ONLY CORRECT TRANSMISSION LUBRICANT FOR A 45 TRACTOR TRANSMISSION. 600 W Steam Cylinder Oil has been used for transmission lubrication, *but its use is not recommended* in the transmissions of "Caterpillar" Tractors. 600 W contains animal fats to make the oil stick to wet surfaces in steam lubrication. In time, in transmission lubrication, the animal fats in 600 W will break down under the action of heat, decompose and render the oil rancid, thus interfering with lubrication. Transmission oil has to circulate between the shaft and the bronze bushing of gears fast enough to carry away the heat generated and afford proper lubrication. UNDER NO CIRCUMSTANCES USE FLAKE OR POWDERED GRAPHITE IN THE TRANSMISSION OIL. IN TIME THIS MATERIAL WILL BE PRECIPITATED OUT OF SOLUTION, DEPOSITED IN THE OIL GROOVES AND ITS REMOVAL CAN ONLY BE EFFECTED WITH A CAPE CHISEL. WHEN THE OIL GROOVES ARE PLUGGED NO TRANSMISSION OIL CAN PERFORM ITS CORRECT FUNCTION.

### Breather Plate and Oil Filler

- 250 — The transmission of the 45 Tractor contains two breather plates, as shown in Fig. 42. These are for the purpose of venting the transmission, thus removing the heat generated by internal friction of the oil. Both of these plates are lipped, and the transmission is protected from the entrance of dirt through the breathers by a fine mesh wire screen placed under the breather plates. In filling the transmission this screen is removed. These screens should be washed with distillate at the required intervals. *In filling the transmission be absolutely on guard to prevent the entrance of dirt with the oil. An oil containing dirt must be treated as a valve-grinding compound. Clean the oil container into which the transmission oil is poured both inside and outside.* When ready to put the oil in the transmission, remove the screen under the breather plate and replace it when finished.

### Transmission Oil Level

- 251 — Fig. 42a shows the transmission oil level plug. This oil level is made extra high for safety. Remove the plug when the tractor is setting level, and, if the oil drain out, *allow to continue until the flow stops, as the oil level is too high, and do not put in additional oil.* When the tractor is new, fill the transmission till the oil runs out of the oil level hole. Fig. 42a, page 13, shows the oil level of the 45 transmission. When the operator becomes familiar with the tractor, he has to govern the transmission oil supply by the amount and character of the work done. If the transmission is completely empty, 6½ gallons will fill the transmission to a cor-

rect level. Too high an oil level makes leaking bearings and a heating transmission. In general, it may be said that only enough oil should be kept in the transmission so that the gears 1475SF will carry the oil up to the oil distributor pan M5945, Fig. 39, to lubricate the steering shaft bevel gear and crankshaft extension No. 2 bearings. *The master clutch must never be connected to revolve the crankshaft extension No. 2 with the shifting lever in neutral position, as the gears 1475SF are not revolving to carry the oil up to the bearings.* When the engine is used on stationary work, disengage the master clutch and be sure that the brake on the universal ring is in good adjustment to prevent turning of all parts back of master clutch.

### Transmission Heating

**252** — In case that a transmission heats, there are three likely causes in the lubrication to account for it:

*First: The oil level may be too high. If the oil level of the transmission is too high, even with the correct mineral transmission oil, heat can be generated very rapidly by the gears churning the oil, thus producing heat by internal friction of the oil itself.* A transmission with the correct oil level should heat but a very few degrees above air temperature. A tractor operator usually errs on the side of having too high an oil level in the transmission. Leaking transmission and steering shaft bearings are caused by having too high an oil level. Study the transmission requirements for the particular tractor handled and reduce the oil level to the proper level.

*Second: The wrong kind of transmission lubricant (a mixture other than straight mineral transmission oil, such as cylinder oil, a semi-fluid grease, mixture of cup grease and cylinder oil, or an extremely heavy transmission oil) may be used, and heating will result as the lack of efficient lubrication regardless of height of oil level.*

**CAUTION:** NEVER USE THE FOLLOWING IN THE TRANSMISSION OF THE 45 OR IN THE TRANSMISSION OF ANY OTHER TYPE ‘‘CATERPILLAR’’ TRANSMISSION:

- a. **GEAR DOPE.**
- b. **PINION LUBRICANT.**
- c. **CUP GREASE.**
- d. **CYLINDER OIL.**
- e. **MIXTURE OF CYLINDER OIL AND CUP GREASE.**
- f. **SEMI-FLUID GREASE.**
- g. **ANY SOLID OR SEMI-SOLID TRANSMISSION COMPOUND REGARDLESS OF CLAIMS MADE.**
- h. **GRAPHITE OR MICA.**

The above are merely pointed out as common mistakes made in transmission lubrication. Transmission lubrication is as exacting as engine lubri-

---

## CARE AND OPERATION

---

cation. Transmission lubrication difficulties can be avoided in using "Caterpillar" Transmission Oil.

*Third:* The oil may contain grit and dirt that will stop up the return oil grooves of the bearings. In the case of the mixture of cup grease and cylinder oil (depending on the material used as a base for the cup grease), the oil grooves may be packed solid with fibre, mica, graphite, resin or other mineral products. Keep transmission oil clean, transport it in clean containers, be careful when filling the transmission not to let dirt fall into the oil or the case.

### The Steering Shaft Assembly

**253** — Fig. 43 shows the steering clutch assembly for the "Caterpillar" 45 Tractor. The steering shaft assembly receives power from 1472SS bevel gear, as shown in Fig. 39. The power is then transmitted through the bevel gears 1473SF to the double clutch M5124. The double clutch M5124 slides over two feather keys 2352SS, and in this way transmits the power to the shaft M4910. The friction driver 5043SF is keyed onto the shaft M4910 by the taper key M4932. The friction driver 5043SF has three arms which engage the male friction 5081SC and the male friction has six springs in sets of twos that force the male friction into contact with the female friction 3422SC. The driving power then extends continuously from the bevel gear 1479SF to the female friction 3422SC. One of the two bevel gears 1473SF drives the steering shaft assembly in reverse direction. To steer the tractor the male friction 5081SC is forced from contact with the female friction 3422SC.

The female friction 3422SC has the spur pinion M4908 keyed to it by the taper key M4930, and this whole assembly rotates free over the shaft M4910. The spur pinion M4908 drives 1475SF (shown in Fig. 39), which in turn drives the external 1476SS and 3429SF, and in turn the track sprocket.

### Steering

**254** — Refer to Fig. 42, which shows the steering lever, steering shaft assembly and track drive sprocket assembly in place. When the hand lever is operated to steer the tractor to the right or left, the motion is transmitted through the two shifter rods which run from one side of the steering shaft assembly to the other on top of the transmission. The shifter rod forces the shifting fork (E2643, Fig. 42) and its attached bronze collar against the shifter collar 3441SF, Fig. 43, which in turn releases the male friction 5081SC from driving the female friction 3422SC and thus releases one of the tracks from driving ahead. A brake operated by the foot can exert pressure to stop the female friction 3422SF from turning, thus facilitating short turning.

**IMPORTANT:** The shifter rods extending across the transmission can be adjusted by means of turnbuckles, *and should be so adjusted at all*

**“CATERPILLAR” 45 TRACTOR**

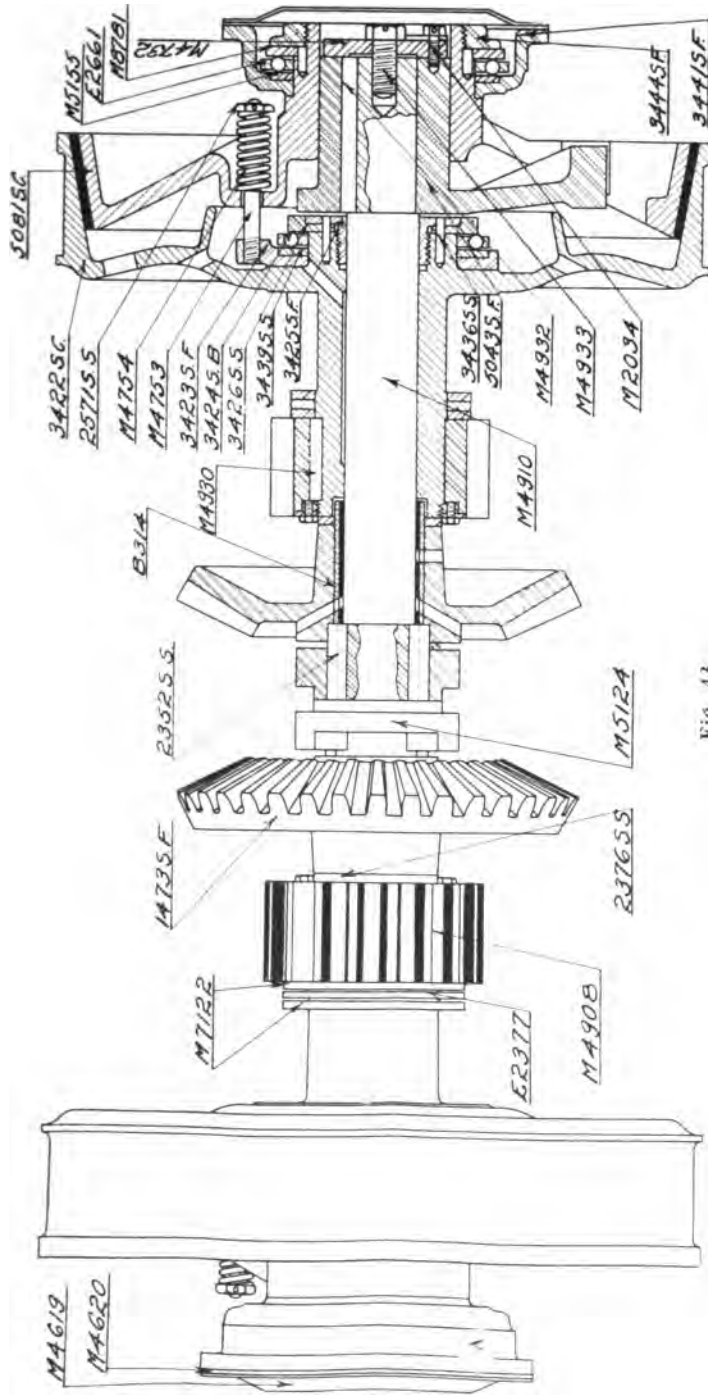

Fig. 43

- A.—Oil Hole
- M4619—End cover
- M4620—Felt washer
- M7122—Thrust washer
- F.2377—Thrust washer
- M4908—Spur pinion
- 1473S.F.—Bevel gear
- 2376S.S.—Washer
- 2352S.S.—Feather key
- M5124—Double clutch
- B.314—Bushing
- M4930—Taper key

- M4910—Shaft
- 5081S.C.—Male friction
- 3422S.C.—Housing
- 2571S.S.—Special nut
- M4754—Spring
- M4753—Stud bolt
- 3423S.F.—Bearing plate
- 3424S.B.—Ball cage
- 3426S.S.—Thrust washer
- 3439S.S.—Thrust washer
- 3425S.F.—Thrust retaining washer
- M4930—Shaft
- 5043S.F.—Friction driver
- M4932—Taper key
- M4933—Special cap screw
- M2034—Cap screw
- M1515—Thrust washer
- F.2661—Ball cage
- M18781—Outer thr. bear. washer
- M4732—Washer
- 3444S.F.—Thrust retaining washer
- 3441S.F.—Shifter collar

---

## CARE AND OPERATION

---

*times that when the hand lever for steering the tractor is moved, about one-eighth of an inch of play will exist between the shifter fork and the shifter collar 344ISF before engagement commences to take place.*

The thrust produced by throwing out the clutch with the shifter fork is taken care of by the ball thrust assembly M5155, E2661 and M8781, Fig. 43. This part should always contain transmission oil, as explained in the paragraph on lubrication of steering shaft assembly.

The band brake should be adjusted so that the brake band double nuts on the housing 3422SC will not bend and retard the action of the brake.

### Adjustment of Male Friction 5081SC.

- 255 — In the course of time the male friction 5081SC may slip. This can be due to two causes.

First: Oil on the clutch surface. Holes are provided in the transmission case, as shown at F and G in Fig. 41. These holes should be unobstructed, so that any free oil can drain from the pit and not get onto the clutch member. The remedy is to wash the oil off of the clutch surfaces with gasoline or distillate and provide for the free escape of any oil from the pit.

Second: The operator in steering the tractor may only partially disengage the clutch, so that the clutch surface will actually spin and rub against the female friction 3422SC, thus producing a wear on the friction lagging. In case this wear has become quite troublesome, it may be possible to prevent slip by increasing the pressure on the springs 2571SF by giving all an equal number of turns. However, this is an adjustment that is not frequently necessary.

### Lubrication of Steering Shaft Assembly

- 256 — All parts of the steering clutch assembly inside of the transmission are lubricated by the transmission oil supply, the oil pan M5945, Fig. 39, pouring the oil over the bevel gear bearings and oilways.

The two bearings of the steering clutch assembly on the transmission case are lubricated by means of sight feed soft oil cups. These oil cups should contain "Caterpillar" Cylinder Oil.

The ball thrust assembly M5155, E2661, M8781 are contained within the shifter collar 3441SF, which collar is made oil tight by a felt washer M4620 and the sheet iron cover M4619, as shown in Fig. 43. At the left hand side of Fig. 43 is shown the countersunk screw, which permits admission of oil to the ball thrust assembly.

**CAUTION:** This countersunk screw may be located as shown in Fig. 43, or may be under the bronze collar on the shifter collar 3441SF. Fig. 42 shows the position of this oil hole as well.

Soft cup grease applied with a grease gun can be used in this ball thrust assembly, but it is advised that "Caterpillar" Transmission Oil be used instead. A hard grease is thrown to the outside by centrifugal action and

**‘‘CATERPILLAR’’ 45 TRACTOR**

remains, while transmission oil will flow to the bottom and immerse part of the thrust members when movement ceases.

Put a small gun of transmission oil in the shifter collar 3441 SF every other day. The operator will have to be guided by the amount required when he becomes familiar with the tractor. Enough oil should be put in so that the lubrication requirement is satisfied and no oil thrown out when the tractor is in operation.

**Track Drive Sprocket Assembly**

**257** — Fig. 44 shows the track drive sprocket assembly for ‘‘Caterpillar’’ 45 Tractor. The external spur gear 3429SF receives its power from the spur

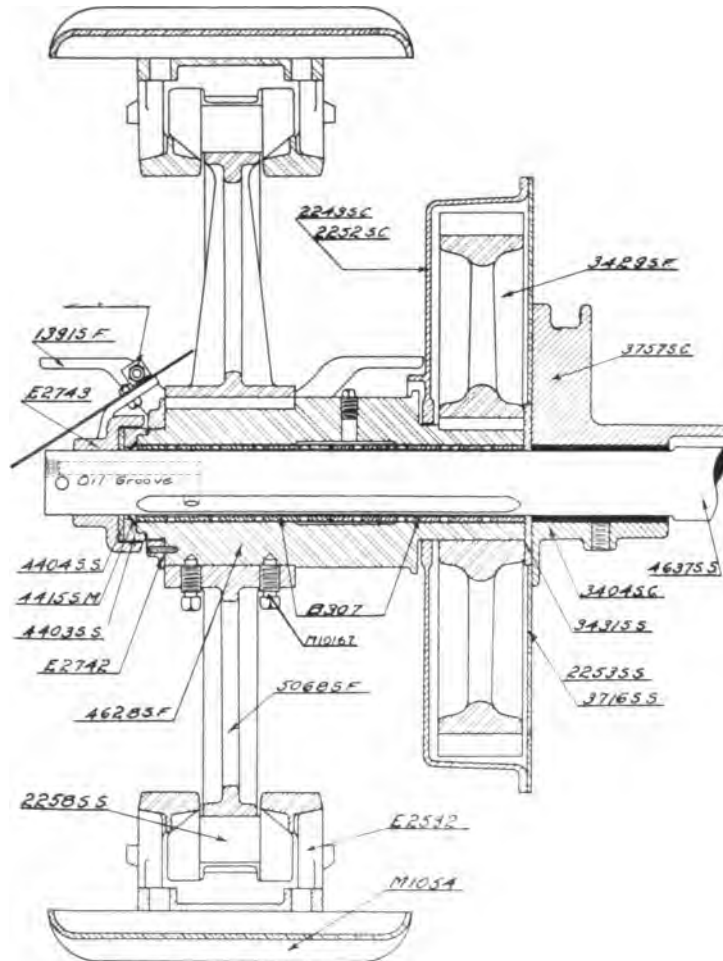

**Fig. 44**

- |                           |                                      |                            |
|---------------------------|--------------------------------------|----------------------------|
| 1391S.F.—Spring seat      | 2243S.C.—Dust guard                  | 3429S.F.—Drive spur gear   |
| E 2743—Thrust rod bearing | 2252S.C.—Dust guard                  | 3757S.C.—Transmission case |
| 4404S.S.—Thrust washer    | B 307—Floating bushing               | 4637S.S.—Drive shaft       |
| 4415S.M.—Dust washer      | M10167—Set screw                     | 3404S.C.—Bearing cap       |
| 4403S.S.—Thrust washer    | 5068S.F.—Track sprocket              | 3431S.S.—Thrust washer     |
| E 2742—Retaining washer   | E 2592—Track link and shoe           | 2253S.S.—Dust guard cover  |
| 4628S.F.—Sleeve hub       | M1054—Coil base and lubricator board | 3716S.S.—Dust guard cover  |
| 2258S.S.—Space block      |                                      |                            |

---

## CARE AND OPERATION

---

pinion 1476SF on the outside of the transmission. Power is then transmitted through the sleeve hub 4628SF, on which the gear 3429SF is keyed. The track sprocket 5068SF containing a split hub slips over a key on the sleeve hub 4628SF, finally meeting a shoulder on the sleeve hub. The bolts through the split hub are then tightened, the set screws M10167 are set up into place, retaining washer E2742 is screwed on the end of the sleeve hub, and this in turn is pinned into place by a set screw which is shown just above the arrow that points to E2742 in Fig. 44.

A felt washer 4415SM is placed over the drive shaft and is held in place by a thrust washer 4403SS, which is made to fit close over the sleeve hub. This felt washer retains the lubricant and excludes the entrance of dirt. A thrust washer 4404SS is placed between the thrust rod bearing E2743 and the balance of the track drive sprocket assembly.

### Floating Bushing

**258** — A floating bushing B307 is placed inside the track drive sprocket hub and is machined so that it can rotate either inside the track drive sprocket hub or over the drive shaft 4637SS. Hence B307 is termed a "floating" bushing. *This part was especially designed so that it could be readily replaced in the field without requiring a machine shop operation to force the old bushing out and seat a new bushing.* The floating bushing should be examined at times, and when worn should be replaced by a new one.

Fig. 45 shows a side view of the external spur gear, oil-tight case, floating bushing and track sprocket. The pinion 1476SF is not considered a member of the track drive sprocket assembly. To effect a repair to the floating bushing or other part of the assembly past the track drive sprocket, it

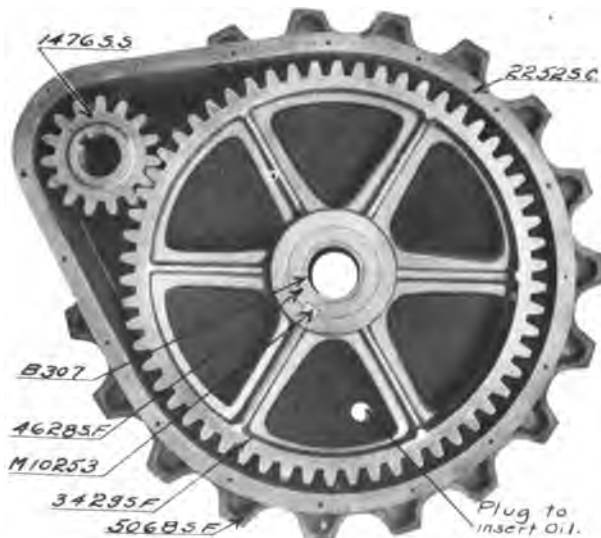

**Fig. 45**

is necessary to cut the track and let it down, un-bolt the oil-tight case 2243SC or 2252SC and remove the track drive sprocket assembly from the drive shaft. If the gasket is destroyed in removing the track drive sprocket assembly, a new one can be readily made out of a heavy grade of roofing paper. Just before reassembling the case give one side of the gasket a heavy coat of shellac, let partly dry, put into place on dust guard, shellac other side of gasket, and bolt dust guard into place. In reassembling be careful that no dirt is allowed to gain admission to any part of the assembly.

## Lubrication of the Track Drive Sprocket Assembly

- 259** — The floating bushing B307 has a large number of staggered holes, together with oil grooves to secure effective distribution of the cup grease. The cup grease is applied through a grease cup on the end of the drive shaft 5637SS and through an oil groove is led to the floating bushing. A plug is provided in the case 2243SC and 2252SC, Fig. 42, so that trans-voir immediately above the track drive sprocket can be filled. ‘‘Caterpillar’’ Transmission Oil should be used in this hub. Fill hub once a day. *The operator must never use a stiff or fibre grease, nor should any grease that is filled with mica or graphite be used. It cannot be impressed upon the operator too strongly that dirt should never be allowed to gain admission to the track drive sprocket hub by being incorporated with the cup grease.*

The external spur gear and pinion working in the oil-tight case, as shown in Fig. 45, should be run in ‘‘Caterpillar’’ Transmission Oil. A plug is provided in the case 2243SC and 2252SC, Fig. 42, so that transmission oil can be inserted. All the lubrication required is sufficient for gear 3429SF to dip one inch. If the track drive assembly has been removed and the dust guard is empty, two quarts of oil is all that is required to fill it to the proper height. The bearing for the pinion 1476SF allows enough oil to come through so that the dust guard need be filled with one quart of oil about once every seven days.

## Truck Frame Assembly

- 260** — Fig. 46 shows a view of the truck frame assembly on the ‘‘Caterpillar’’ 45 Tractor. The truck frame assembly consists of two truck frames employing two truck wheels and the other three, both frames being hinged on the pivot shaft 4635SS, and in turn the pivot shaft 4635SS is hinged to the frame channel by the radial arm E2594.

The truck frames are kept in line by the angle iron 4636SS and 4634SS.



## CARE AND OPERATION

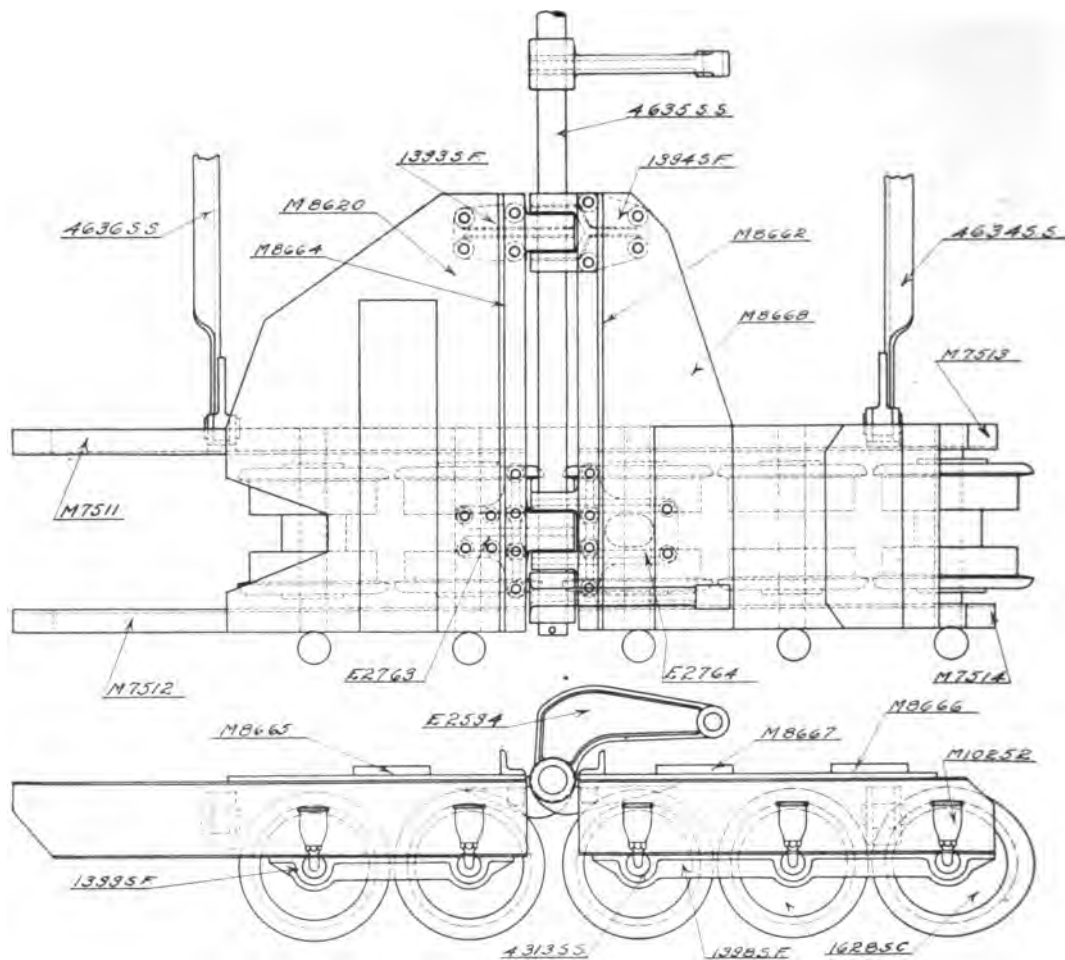

**Fig. 46**

- |  |   |
|--|---|
| 1393.S.F.—Hinge                            | M8620—Truck frame plate, R. H.              |
| 1394.S.F.—Hinge                            | M8662—Angle for rear truck frame, L. H.     |
| 1398.S.F.—Gudgeon bracket                  | M8664—Angle for front truck frame, L. H.    |
| 1399.S.F.—Gudgeon bracket                  | M8665—Flat for front truck frame            |
| 1628.S.C.—Truck wheel                      | M8666—Flat for reinforcing rear truck frame |
| 4313.S.S.—Gudgeon                          | M8667—Flat for reinforcing rear truck frame |
| 4634.S.S.—Angle—Rear cross ties            | M8668—Rear truck frame plate                |
| 4635.S.S.—Pivot shaft                      | M7511—Truck side plate                      |
| 4636.S.S.—Angle—Front cross ties           | M7512—Truck side plate                      |
| E 2594—Thrust rod                          | M7513—Truck side plate                      |
| E 2763—Hinge roller frame, outside, male   | M7514—Truck side plate                      |
| E 2764—Hinge roller frame, outside, female | M10252—Cup-funnel oil                       |

## To Adjust Truck Frames

The truck frames should be kept in adjustment so that the track drive sprocket No. 25, Fig. 34, will have equal clearance on each side of the slot

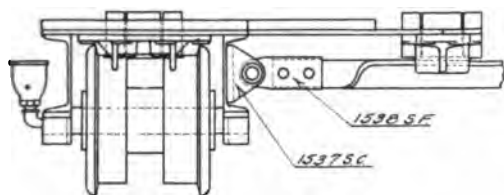

Fig. 47

1538SF—Rod end  
1537SC—Bracket

in the rear truck wheel. To adjust the trucks onto line, it will be necessary to remove the cross ties and lengthen or shorten them in a forge. Fig. 47 shows the method of attachment of the cross ties to the truck frame. The hinges 1393SF, 1394SF, E2763 and E2764 are set onto the truck frame M668 and M8620 with reamed

holes and drive fit bolts. Inspection should be made occasionally, tightening nuts where required and keeping the hinges solid on the frame.

## Truck Wheels

261 — Fig. 48 shows a cross section view of the truck wheel on the “Caterpillar” 45 Tractor. All truck wheels on the 45 Tractor have outside flanges and are lubricated with soft oil cups

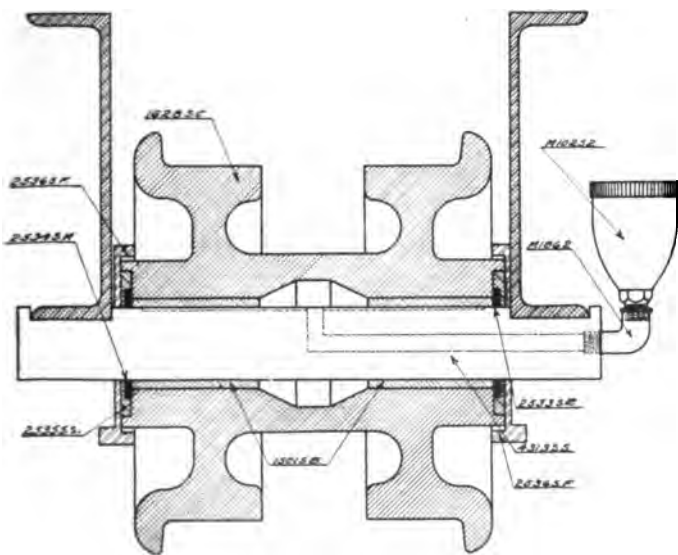

Fig. 48

1501SB—Bushing	2536SF—Dust collar
1628SC—Truck wheel	4313SS—Gudgeon
2533SR—Washer	M1862—Street eH, 3/8"
2534SM—Washer	M10252—Cup-funnel
2535SS—Dust washer	

instead of grease cups. The truck wheels contain two bronze bushings 1501SB driven in from each end and leaving a recess in the metal of the truck wheel. At the end of the truck wheel a felt washer is provided to retain the soft oil against which the washer 2535SS fits. Over this assembly the dust collar 2536SF fits to exclude dirt from gaining admission between the hub of the truck wheel and the dust collar. It is advised

that the operator make a careful inspection of the dust collars 2536SF and replace these parts when worn or broken, as it is vital to exclude the dirt from gaining admission at this point.

## Lubrication of Truck Wheels

- 262 — Truck wheels on the "Caterpillar" 45 Tractor are lubricated with soft oil supplied in M10252. *This oil should be a transmission oil or a good grade of black oil.* **CAUTION:** NEVER UNDER ANY CIRCUMSTANCES USE CRUDE OR FUEL OIL FOR THE LUBRICATION OF TRUCK WHEELS. Crude and fuel oil contain sand, which in turn produces rapid wear. Every precaution has been made in the manufacture of the truck wheel to exclude dirt. Use only a refined track oil or a transmission oil in the truck wheel. The operator will have to be governed by the amount of oil that the truck wheel requires, but on average work they only require a half a pint of oil each a day per ten-hour day.

## "Caterpillar" Track

- 263 — The track on the "Caterpillar" 45 Tractor is a flexible, endless belt composed of steel links and shoes cast integral, connected by case-hardened sleeves and case-hardened track pins. From "Caterpillar" 45 Tractor No. 20142 and on, the construction of the track is what is known as the 72-inch center, meaning that the track is 72 inches from center to center. The track employed with the 72-inch track is such that the track plates can be removed and the 8-inch integral track shoe and links will remain in place, giving a very narrow track for special service. Depending upon the width of track desired by the customer, 16, 20, 24 or 28 inch track plates can be bolted on the 8-inch integral shoe, thus giving a variety of track widths with the original chain. Twenty-inch track shoes are standard equipment.

Fig. 49 shows a view of the parts that go to make up a track. Reading from left to



right are shown track shoe, case-hardened sleeve, case-hardened pin, 8-inch integral track shoe and rails,

Fig. 49

and then the integral link with the 20-inch track shoe assembled in place.

## Adjustment on Case-Hardened Sleeves

- 264 — When wear occurs on the case-hardened sleeve so as to produce an undue amount of slack in the track, the track pins can be removed and the sleeves

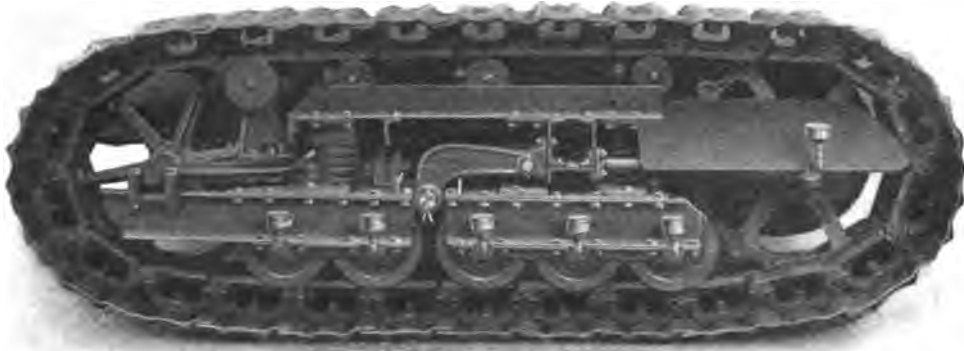

Fig. 50

turned over, thus producing a new surface for wear and giving full service on the track sleeve. Fig. 50 shows the side view of the complete track, truck frame and track drive sprocket assembly.

## To Adjust the Track

- 265 — Refer to Fig. 34. After a period of use the track will be in need of adjustment to take up the slack. This adjustment is made by forcing the fork for track idler No. 41 forward by means of the thrust rod adjusting nut No. 37. *The track should not be kept too tight*, neither should it be allowed to run with an undue amount of slack in it. The average operator adjusts the track so that it is possible to lift the track clear of two track carrier rollers by backing up to it, putting the hands at the small of the back and gripping the track shoes lift the track. The tracks on each side of the tractor can be adjusted independently of one another.

## Lubrication of Track

- 266 — The only time that the tracks can be lubricated is when the tractor is in motion. The tracks should be well flooded with black oil about once an hour; however, many operating conditions vary and the engineer has to use his judgment in most cases. **CRUDE OR FUEL OIL SHOULD NEVER BE USED FOR TRACK LUBRICATION, AS THEY CONTAIN SAND IN VARYING AMOUNTS AND HAVE NO DIRECT LUBRICATING VALUE.** In addition crude or fuel oil will build up a deposit of asphaltum

---

## CARE AND OPERATION

---

on the outside of the track side bars and prevent the entrance of oil to the space block and pin. As long as the track pin and space block have a film of oil, additional lubrication will not be required. A better quality of oil than crude or fuel oil will give longer lubrication, a less quantity will be required and the wear on the track will be reduced to a minimum. The track oil is carried in two reservoirs on either side of the tractor and is distributed to the tracks by hose connections. A valve governs the flow of the oil.

## MISCELLANEOUS DATA

---

### Relation of Size and Speeds of Driving and Driven Pulleys

Let  $D$  equal *diameter of driving pulley*.

“  $d$  equal *diameter of driven pulley*.

“  $R$  equal *revolutions per minute driving pulley*.

“  $r$  equal *revolutions per minute of driven pulley*.

Then

$$d \text{ equals } D \times R \text{ divided by } r \quad d = \frac{DR}{r}$$

$$r \text{ equals } D \times R \text{ divided by } d \quad r = \frac{DR}{d}$$

$$D \text{ equals } d \times r \text{ divided by } R \quad D = \frac{dr}{R}$$

$$R \text{ equals } d \times r \text{ divided by } D \quad R = \frac{dr}{D}$$

The stationary shaft speed of the 45 is 625 revolutions per minute at 600 R. P. M. of engine. The standard pulley furnished is 14 inches in diameter.

With the above equipment suppose it is desired to run a certain shaft at 1000 revolutions per minute and it is required to determine the diameter of the small pulley.

$$d = D \times R \text{ divided by } r.$$

$$d = \frac{625 \times 14}{1000} = 8.75". \text{ As pulleys are only made in standard sizes it will}$$

be necessary to use a 9-inch pulley.

---

**CARE AND OPERATION**

---

## Increasing Belt Speed by Lagging Driving Pulley

It is possible to increase the belt speed by lagging the *driving* pulley with leather or rubber belting. Lagging the *driven* pulley, however, will reduce the speed.

### Plowing Table

**ACRES PLOWED PER TEN-HOUR DAY.**

No. of Bottoms.	Shares—Width in inches.	Total width of cut in inches.	SPEED OF TRACTOR, MILES PER HOUR.				
			1.5 acres.	2.00 acres.	2.25 acres.	2.50 acres.	3.0 acres.
1.....	10	10	1.5	2.0	2.25	2.5	3.0
	12	12	1.8	2.4	2.7	3.0	3.6
	14	14	2.1	2.8	3.15	3.5	4.2
2.....	10	20	3.0	4.0	4.5	5.0	6.0
	12	24	3.6	4.8	5.4	6.0	7.2
	14	28	4.2	5.6	6.30	7.0	8.4
3.....	10	30	4.5	6.0	6.75	7.5	9.0
	12	36	5.4	7.2	8.1	9.0	10.8
	14	42	6.3	8.4	9.45	10.5	12.6
4.....	10	40	6.0	8.0	9.0	10.0	12.0
	12	48	7.2	9.6	10.8	12.0	14.4
	14	56	8.4	11.2	12.6	14.0	16.8
5.....	10	50	7.5	10.0	11.25	12.5	15.0
	12	60	9.0	12.0	13.5	15.0	18.0
	14	70	10.5	14.0	15.75	17.5	21.0
6.....	10	60	9.0	12.0	13.5	15.0	18.0
	12	72	10.8	14.4	16.2	18.0	21.6
	14	84	12.6	16.8	18.9	21.0	25.2
7.....	10	70	10.5	14.0	15.75	17.5	21.0
	12	84	12.6	16.8	18.9	21.0	25.2
	14	98	14.7	19.6	21.05	24.5	29.4
8.....	10	80	12.0	16.0	18.0	20.0	24.0
	12	96	14.4	19.2	21.6	24.0	28.8
	14	112	16.8	22.4	25.2	28.0	33.6
9.....	10	90	13.5	18.0	20.25	22.5	27.0
	12	108	16.2	21.6	24.3	27.0	32.4
	14	126	18.9	25.2	28.35	31.5	37.8
10.....	10	100	15.0	20.0	22.5	25.0	30.0
	12	120	18.0	24.0	27.0	30.0	36.0
	14	140	21.0	28.0	31.5	35.0	42.0
12.....	10	120	18.0	24.0	27.0	30.0	36.0
	12	144	21.6	28.8	32.4	36.0	43.2
	14	168	25.2	33.6	37.8	42.0	50.4
14.....	10	140	21.0	28.0	31.5	35.0	42.0
	12	168	25.2	33.6	37.8	42.0	50.4
	14	196	29.4	39.2	44.1	49.0	58.8

# INDEX

<b>Babbitt</b>	<b>Paragraphs</b>
grade of, used in engine bearings.....	61
grade of, used in transmission bearings.....	249
scraper, how to make.....	81
<b>Bearings</b>	
when to try for looseness.....	61 and 62
cause of continuous bearing trouble.....	72
correct procedure removal of shims.....	70 and 71
determination of loose crankshaft bearings.....	63
determination of loose crankpin bearings.....	64
determination of loose wrist pin bearings.....	65
crankshaft bearings, how classified.....	148
fitting caps to.....	78
fitting connecting rod.....	80
relieve side of.....	79
<b>Carbureter</b>	
general discussion.....	148 to 151
all air must go through carbureter.....	151 to 153
before adjusting, valves must open correctly.....	154
before adjusting, magneto must be correctly timed.....	180 and 223
adjusting, air valve and needle valve.....	157 and 158
adjusting, float.....	162
adjusting, float valve.....	163
cork gasket "N".....	164
over-lean mixture.....	160
over-rich mixture.....	161
<b>Cooling System</b>	
general discussion.....	197
removal of scale.....	225
radiator, care of and repair.....	198 to 205
<b>Cylinders</b>	
general discussion.....	92
water jackets, keep free from sediment and scale.....	93
dry air cleaning device used to prevent wear on.....	94 to 97
scoring of, due to.....	100 to 104
reboring.....	104 and 105
assembling, rebored job.....	106
running with "missing" cylinder, effect of.....	91
fitting cylinder head gaskets.....	98 and 99



## INDEX—Continued

	Paragraphs
<b>Engine</b>	
general care of.....	48 and 49
oil level adjustment.....	51 to 54
starting.....	12 to 20
overheating.....	224 and 225
knocks.....	232
timing.....	214 to 223
stopping.....	30 to 36
<b>Governor</b>	
general discussion.....	143
adjustment.....	144
plunger and spring adjustment.....	145
bronze washer.....	146
<b>Knocks</b>	
general discussion.....	83 to 91
<b>Lubrication</b>	
general discussion lubrication and friction.....	36 to 41
requirements of the "Caterpillar" Tractor.....	41
care of lubrication oil, cup grease and transmission oil.....	42 to 47
lubricating chart .....	44
how to clean crankcase doors.....	49
how to clean crankcase.....	58 to 61
examine condition of oil in crankcase.....	56 and 57
clean oil pump and screen.....	54 and 55
lubrication of governor.....	147
lubrication of HK K-W magneto.....	177
"    " TK K-W magneto .....	194
"    " water pump .....	213
"    " valve stems .....	138
"    " master clutch .....	240
"    " transmission .....	249 and 250
"    " steering shaft .....	256
"    " track drive sprocket assembly.....	259
"    " truck wheels .....	261
"    " track .....	266
"    " starting and stationary attachment.....	237
<b>Magneto</b>	
Model HK K-W.....	174 to 184
Model TK K-W.....	185 to 196
timing to engine.....	223
troubles.....	195
<b>Master Clutch</b>	
general discussion .....	238 to 242

## INDEX—Continued

	Paragraphs
<b>Pistons</b>	
function, shape, oil grooves, wristpin hole, wrist pin.....	107 to 113
removing from cylinders.....	118 to 120
piston ring slots, care of.....	115 to 118
cleaning piston ring slot.....	125 and 126
<b>Piston Rings</b>	
general discussion of fitting.....	120
fitting ring in cylinder.....	121 to 125
fitting ring in piston ring slot.....	127 to 132
importance of piston ring fit.....	133
handling piston rings, care required.....	134
<b>Starting</b>	
engine.....	12 to 19 and 234
load.....	20 to 23
<b>Stationary Attachment</b>	
general description.....	233 to 237
<b>Steering Clutch Assembly</b>	
general discussion.....	253 to 257
<b>Stopping</b>	
engine.....	32 to 36, 165 and 166
tractor.....	30 to 35
<b>Timing</b>	
engine.....	214 to 224
magneto.....	180
<b>Track</b>	
care and adjustment.....	263 to 266
<b>Track Drive Sprocket Assembly</b>	
general discussion.....	257 to 260
<b>Transmission</b>	
care and adjustment.....	244 to 253
<b>Trucks</b>	
care and adjustment.....	260 to 263
<b>Troubles</b>	
miscellaneous engine.....	226 to 231
<b>Universal Coupling and Brake</b>	
general discussion.....	243
<b>Vacuum System</b>	
care and adjustment.....	168 to 173
<b>Water Pump</b>	
care and adjustment.....	212 and 213







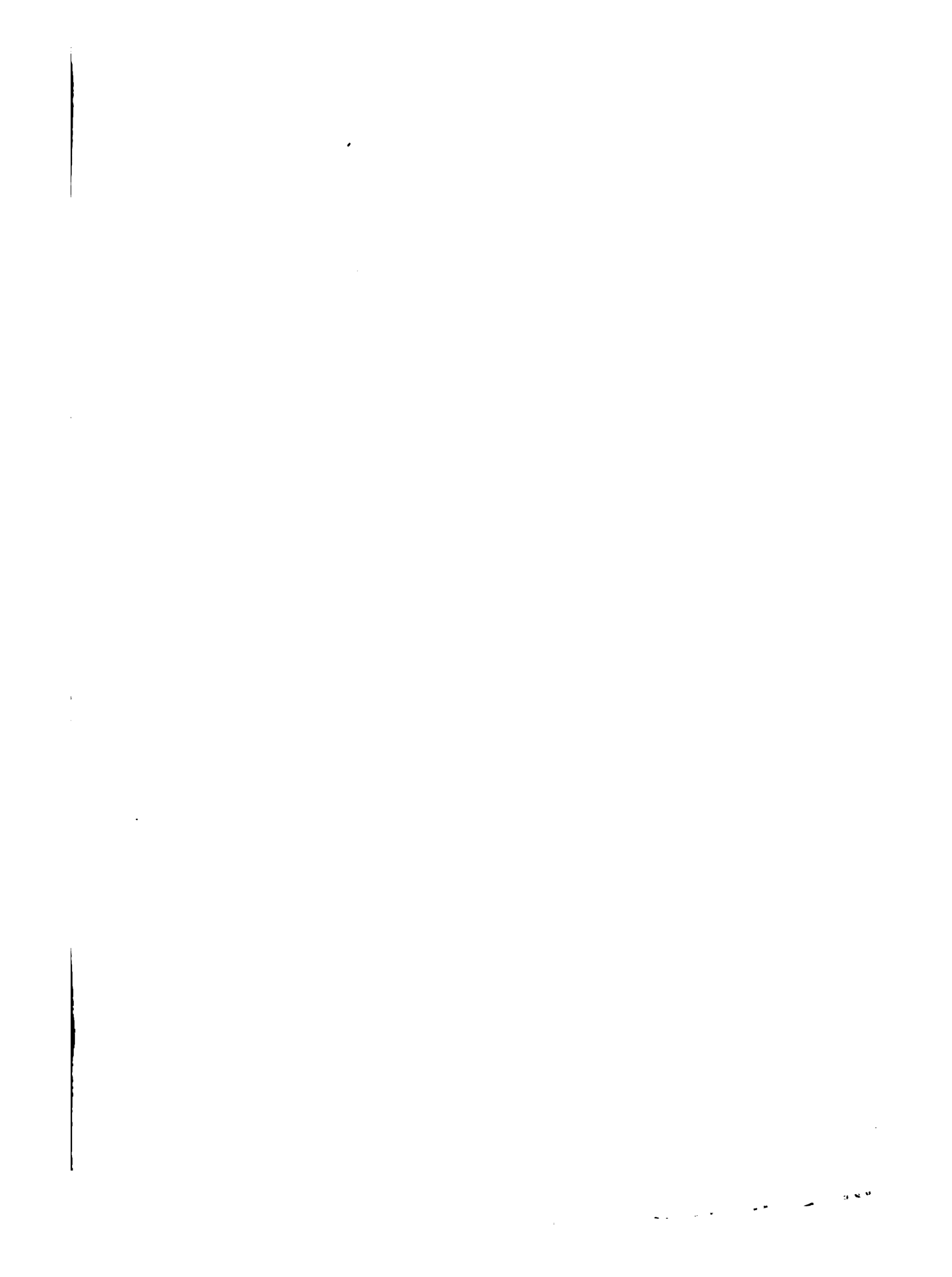

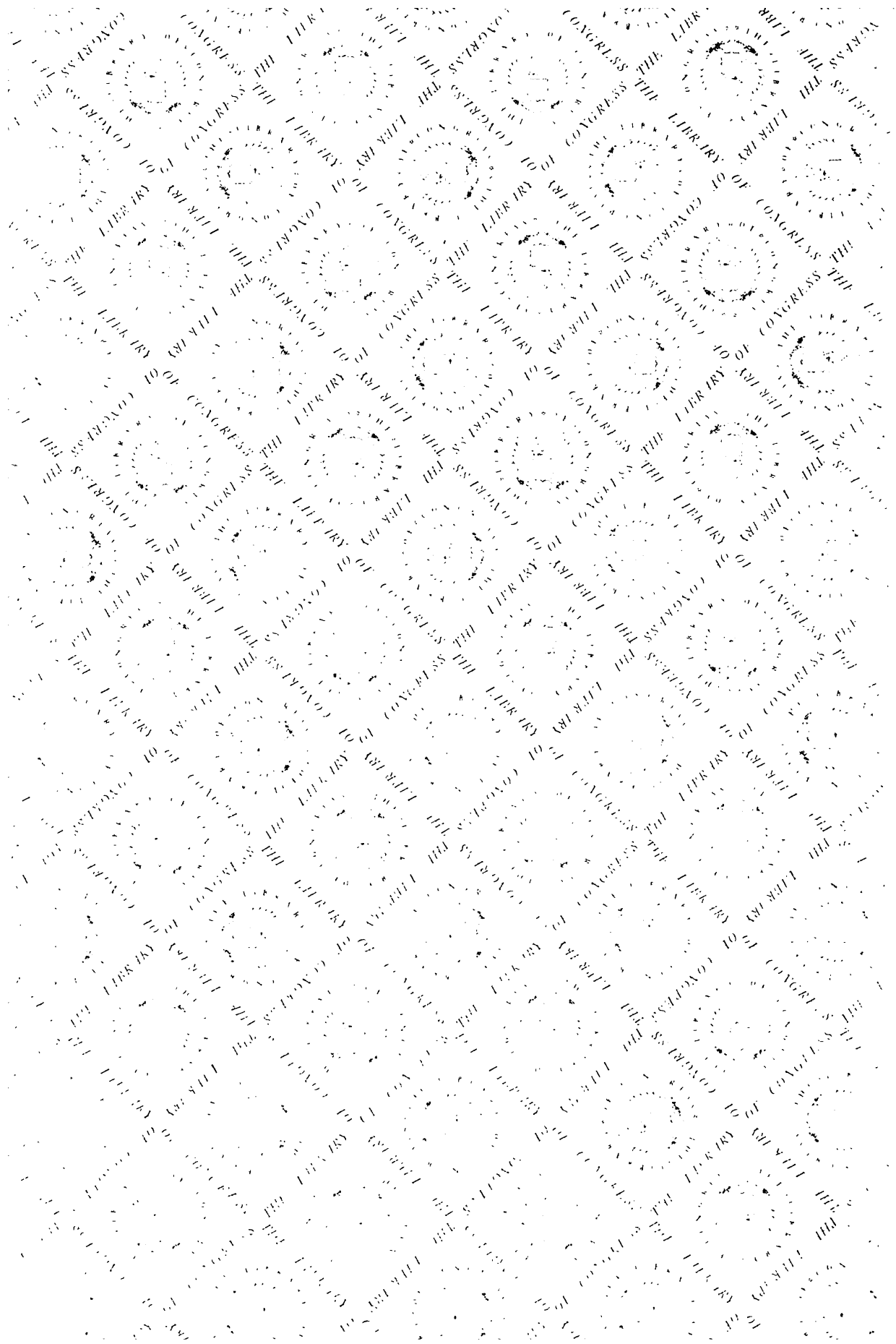

THE LIBRARY OF CONGRESS  
SERIALS ACQUISITION  
510 MAZOUZ DRIVE  
COLUMBIA, MD 21046  
TEL: 301 709 8300  
FAX: 301 709 8300  
WWW.LIBRARY OF CONGRESS.GOV

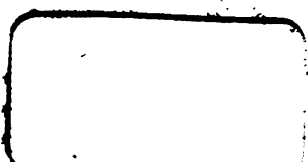



LIBRARY OF CONGRESS



0 013 398 586 4 